

DYNAPAC CA 602 MAINTENANCE

M602EN2

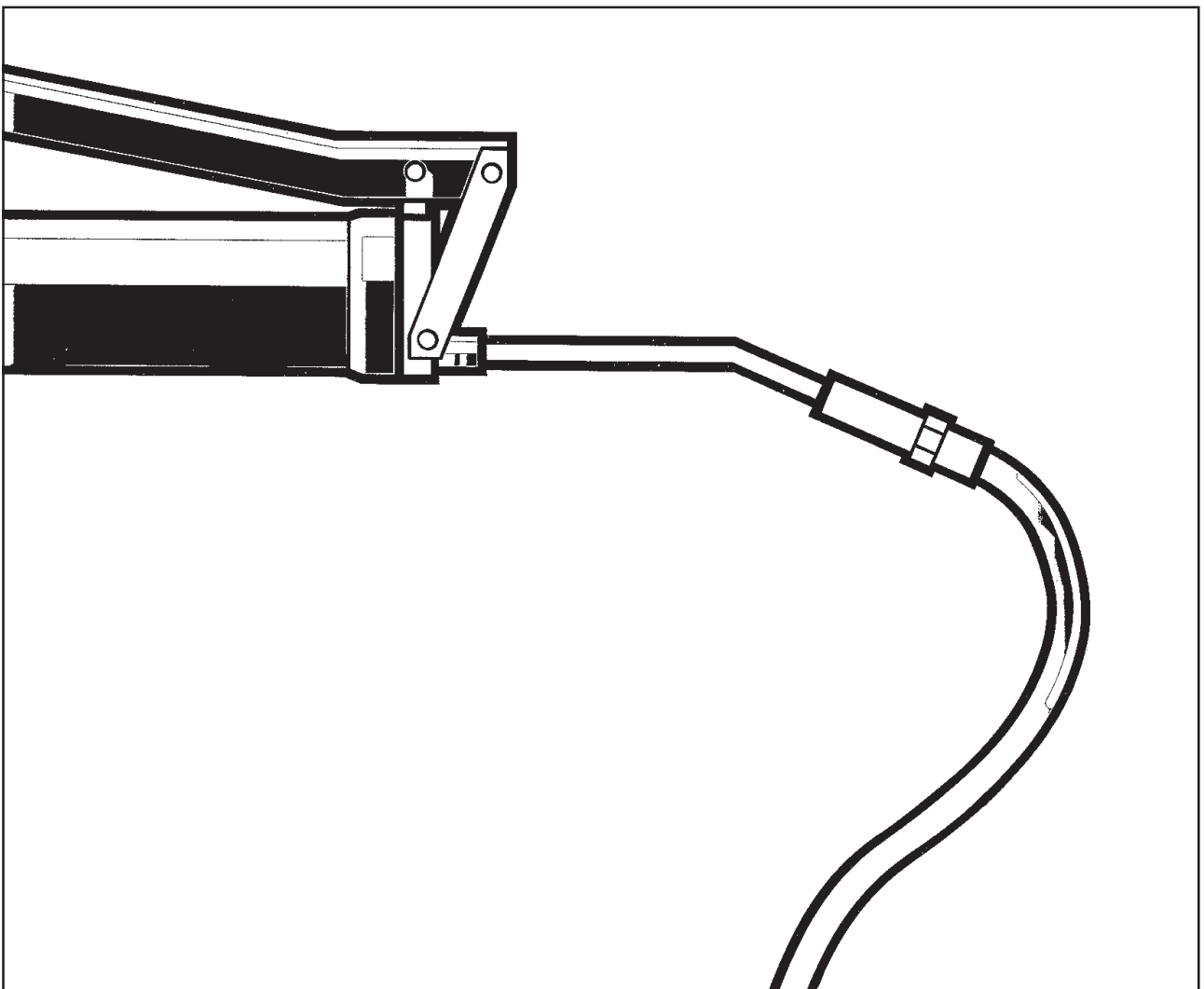

DYNAPAC
Metso Dynapac AB

Box 504, SE-371 23 Karlskrona, Sweden

Telephone +46 455 30 60 00

Telefax +46 455 30 60 30

Web www.dynapac.com

DYNAPAC

Vibratory Roller CA 602

Maintenance M602EN2, August 2003

**Diesel engine:
CA 602: Cummins QSB 5.9-C**

**These instructions apply from:
CA 602 PIN (S/N) *71420603***

**KEEP THIS MANUAL FOR
FUTURE REFERENCE**

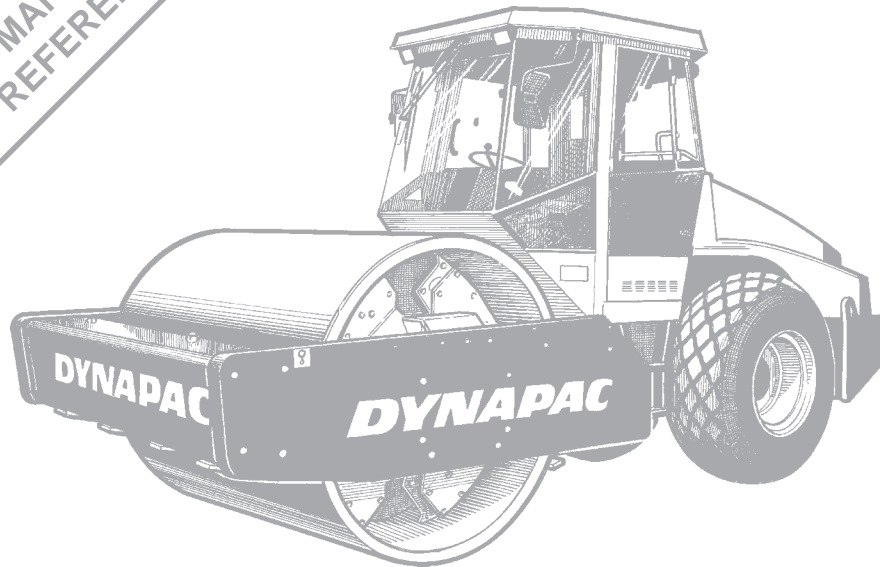

The Dynapac CA 602 is available in D (smooth drum) and PD (padfoot) versions, of which the CA 602D is designed for compacting rock fill. The main range of application for the PD versions is on cohesive material and weathered stone material.

All types of base courses and subbase courses can be compacted deeper and the interchangeable drums, D to PD, and vice versa, facilitate even greater variety in the range of application.

Certain accessories, such as the compaction meter, tachograph and the CCS/RA field computer, are described in separate instructions.

CONTENTS

	Page
Lubricants and symbols	3
Technical specifications	4-6
Maintenance schedule	7
Maintenance measures	8-9
Every 10 hours of operation (Daily)	10-12
Every 50 hours of operation (Weekly)	13-15
Every 250 hours of operation (Monthly)	16-20
Every 500 hours of operation (Every three months)	21-22
Every 1000 hours of operation (Every six months)	23-25
Every 2000 hours of operation (Yearly)	26-29
Long-term storage	30
Special instructions	31
Electrical system, fuses	32-34

WARNING SYMBOLS

WARNING



Safety instruction – Personal Safety

CAUTION



Special caution – Machine or component damage

GENERAL

WARNING



Read through the entire manual before starting any maintenance operations.

WARNING



Ensure good ventilation (air extraction) if the diesel engine is run indoors.

WARNING



If the gas-springs of the hood are out of action and the hood is put at its upper position – block the hood so that it cannot fall.

It is important that the roller is maintained correctly to ensure proper function. It should be kept clean so that any leakage, loose bolts and loose connections can be discovered in time.

Make a habit of inspecting the roller every day before starting up by checking all round and underneath the machine to detect any sign of leakage or other faults.

SPARE A THOUGHT FOR THE ENVIRONMENT! Do not let oil, fuel and other environmentally hazardous substances contaminate the environment.

This manual contains instructions for periodic measures that should normally be performed by the operator.

CAUTION



There are additional instructions relating to the diesel engine, for which the manufacturer's instructions are detailed in the engine manual. This is found under a separate flap in the roller's product binder.

CALIFORNIA









Proposition 65 Warning

Diesel engine exhaust and some of its constituents are known to the State of California to cause cancer, birth defects, and other reproductive harm.

LUBRICANTS AND SYMBOLS















Always use high-quality lubricants, in the quantities specified. Excess grease or oil can promote overheating, resulting in premature wear.

	ENGINE OIL	Shell Universal SAE 15W/40 or equivalent API Service CF-4/SG, (CD/CE)
	HYDRAULIC FLUID ambient air temperature -10°C – +40°C (14°F - 104°F) ambient air temperature above +40°C (above 104°F)	Shell Tellus TX68 or equivalent Shell Tellus TX100 or equivalent
	BIODEGRADABLE HYDRAULIC FLUID	Shell Naturelle HF-E46 When it leaves the factory, the machine may be filled with biologically degradable fluid. The same type of fluid must be used when changing or topping off.
	TRANSMISSIONSOLJA ambient air temperature -15°C – +40°C (5°F - 104°F) ambient air temperature above +40°C (above 104°F)	Shell Spirax SAE 80W/90, HD API, GL-5 Shell Spirax HD85W/140 or equivalent
	DRUM CARTRIDGE OIL	Mobil SHC 629
	GREASE	SKF LGHB2 (NLGI Class 2) or equivalent for the articulated joint Shell Retinax LX2 or equivalent for other grease points
	FUEL	See the engine manual
	COOLANT mixed 50/50 with water	GlycoShell or equivalent Anti-freeze protection down to about -41°C (-106°F).



Other fuel and lubricants are required for operation in extremely high or extremely low ambient temperature. See the “Special instructions” chapter, or consult Dynapac.

	Engine, oil level		Air pressure
	Engine, oil filter		Air filter
	Hydraulic fluid tank, level		Battery
	Hydraulic fluid filter		Recycling
	Transmission, oil level		Fuel filter
	Drum, oil level		Coolant, level
	Oil for lubrication		

TECHNICAL SPECIFICATIONS

Weights & dimensions	CA602D	CA602PD
Operating mass with ROPS, EN500, kg (lbs)	18600 (41006)	18600 (41006)
Operating mass without ROPS, kg (lbs)	18100 (39904)	18100 (39904)
Operating mass with cab, kg (lbs)	18600 (41006)	18600 (41006)
Length, standard-equipped roller, mm (in)	6000 (236)	6000 (236)
Width, standard-equipped roller, mm (in)	2380 (94)	2380 (94)
Height, with ROPS, mm (in)	2929 (115)	2987 (117)
Height, without ROPS, mm (in)	2134 (84)	2208 (87)
Height, with cab, mm (in)	2952 (116)	2987 (118)

Fluid volumes, litres (gal or qts) CA 602

Rear axle:	
• Differential	12 (12.7 qts)
• Planetary gears	1,8 (1.9 qts)/each side
Drum gearbox	3,5 (3.7 qts)
Drum cartridge	2,2 (2.3 qts)/each side
Hydraulic reservoir	52 (13.7 gal)
Oil in hydraulic system	43 (11.4 gal)
Lubrication oil, diesel engine	14 (14.8 qts)
Coolant, diesel engine	26 (6.9 gal)
Fuel tank	320 (84.5 gal)

Electrical system

Battery	12 V, 170 Ah
Alternator	14 V, 105 A / 95 A
Fuses	See under heading "Electrical System"

Tires (all-weather)

Tire dimensions	23.1 x 26.0 8 Ply, 600/60-30,5
Tire pressure	110 kPa (1,1 kp/cm ²) (16 psi)

WARNING



The tires can be optionally filled with fluid, (extra weight up to 700 kg/tire) (1,544 lbs/tire). When servicing, bear this extra weight in mind.

Vibration data	CA602D	CA602PD
Static linear load, kg/cm (pli)	59,6 (334)	—
Amplitude (High), mm (in)	1,8 (0.07)	1,8 (0.07)
Amplitude (Low), mm (in)	1,1 (0.04)	1,1 (0.04)
Frequency (High/Low ampl.), Hz (vpm)	27/31 (1620/1860)	27/31 (1620/1860)
Centrifugal force (High amplitude), kN (lb)	276 (62,100)	276 (62,100)
Centrifugal force (Low amplitude), kN (lb)	229 (51,525)	229 (51,525)

TECHNICAL SPECIFICATIONS

Tightening torque

Tightening torque in Nm (lbf.ft) for oiled, bright galvanized bolts tightened with a torque wrench.

M thread	STRENGTH CLASS		
	8.8	10.9	12.9
M6	8,4 (6.2)	12 (8.9)	14,6 (10.8)
M8	21 (15.5)	28 (20.7)	34 (21.1)
M10	40 (15.5)	56 (41.3)	68 (25.1)
M12	70 (51.6)	98 (72.3)	117 (86.3)
M16	169 (124.7)	240 (177)	290 (213.9)
M20	330 (243.4)	470 (346.7)	560 (413.1)
M24	570 (420.4)	800 (590.1)	960 (708.1)
M30	1130 (833.5)	1580 (1165.4)	1900 (1401.4)
M36	1960 (1445.7)	2800 (2065.3)	–

ROPS

CAUTION



ROPS bolts must **always** be tightened dry.

Bolt size:	M24 (P/N 90 39 64)
Strength class:	10.9
Tightening torque:	800 Nm (590 lbf.ft) (for Dacromet treated)

Hydraulic system

Opening pressure, MPa (psi)	
Drive system	38,0 (5,500)
Charge system	2,0 (290)
Vibration system	37,5 (5,400)
Steering system	18,0 (2,600)
Brake release	1,4 (200)

TECHNICAL SPECIFICATIONS

Vibrations - Drivers seat (ISO 2631)

The vibration values are measured in conformance with the driving mode described in EU directive 2000/14/EC on EU equipped machines, on soft polymer material with vibration switched ON and the operator's seat in transport mode.

Whole-body vibration is measured at less than the action value of 0.5 m/s² specified in EU directive 2002/44/EC. (The limit value is 1.15 m/s².)

Hand/arm vibration is measured at less than the action value of 2.5 m/s² specified in the same directive. (The limit value is 5 m/s².)

CAUTION



Vibration levels may vary when driving on different courses and with different seat positions.

Acoustic values

The acoustic values are measured in conformance with EU directive 2000/14/EC on EU-equipped machines, on soft polymer material with vibration switched ON and the operator's seat in transport mode.

Model	Guaranteed acoustic power level dB(A)	Acoustic pressure level, operator's ear (platform) dB(A)	Acoustic pressure level, operator's ear (cab) dB(A)
CA 602	111	87	79

CAUTION



Noise level can vary when driving on different courses and with different seat positions.

MAINTENANCE SCHEDULE

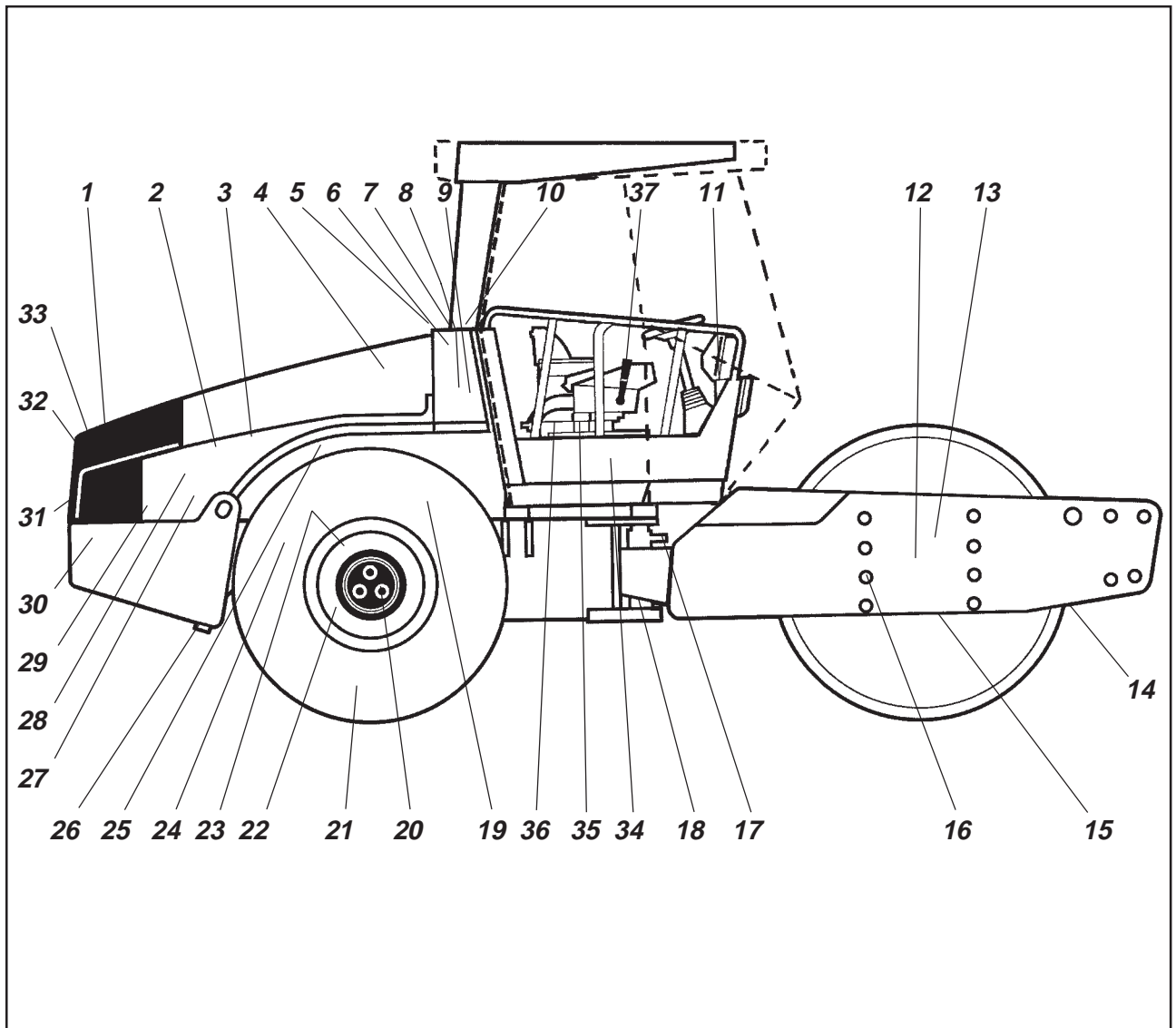

Fig. 1 Service and maintenance points

- | | | |
|---|--|-------------------------------------|
| 1 Radiator grille | 14 Scrapers | 27 Diesel engine mountings, 4 pcs. |
| 2 Oil level, diesel engine | 15 Drum cartridge oil, level plugs, 2 pcs. | 28 Feed pump, fuel |
| 3 Fuel filter, initial fuel filter | 16 Rubber elements and attachment screws | 29 Diesel fuel, filler |
| 4 Air filter | 17 Steering joint | 30 Battery |
| 5 Engine cover, hinges | 18 Steering cylinders, 2 pcs. | 31 Radiator |
| 6 Hydraulic fluid reservoir, sightglass | 19 Flywheel casing, hydraulic pumps | 32 Hydraulic fluid cooler |
| 7 Bleeding filter | 20 Wheel nuts | 33 Drive belts, cooling, alternator |
| 8 Hydraulic fluid filters (2 filters) | 21 Tires, pressure | 34 Steering chain |
| 9 Drainage, hydraulic fluid reservoir | 22 Rear axle, differential | 35 Seat bearing |
| 10 Hydraulic fluid, filler | 23 Rear axle, planetary gears, 2 pcs. | 36 Steering chain |
| 11 Fuse-box | 24 Rear axle suspension, 2 sides | 37 Forward/Reverse lever |
| 12 Drum cartridge, filling, 2 fillers | 25 Oil filter, diesel engine | |
| 13 Drum gearbox | 26 Drainage, fuel tank | |

MAINTENANCE MEASURES

The periodic measures should be performed primarily after the specified hours of operation. Use the daily, weekly, etc. time periods only where this is not possible.

CAUTION



Remove all dirt before filling, when checking oils and fuel, and when lubricating with oil or grease.

CAUTION



The engine manual specifies additional service/maintenance instructions which relate to the diesel engine.

Every 10 hours of operation (Daily)

Item. in fig. 1	Measure	See page	Comments
	Before starting each day		
14	Check scraper setting	10	
1	Check for free circulation of cooling air	10	
31	Check coolant level	11	See engine manual
2	Check diesel engine oil level	11	See engine manual
29	Top up fuel tank	12	
6	Check fluid level in hydraulic reservoir	12	
	Check brakes	12	

Every 50 hours of operation (Weekly)

Item. in fig. 1	Measure	See page	Comments
	Check that hoses and couplings are not leaking		
7	Inspect/clean the filter element in the air cleaner	13	Replace as required
17	Lubricate steering joint	14	
18	Lubricate steering cylinders' attachments	14	
20	Check the wheel-nuts are tightened	15	
21	Check tire pressure	15	
	Inspect the air conditioning	15	Optional

CAUTION



After the **first** 50 hours of operation, change only the drum oil and all the oil filters.

MAINTENANCE MEASURES

Every 250 hours of operation (Monthly)

Item. in fig. 1	Measure	See page	Comments
23	Check oil level in rear axle/planetary gearing	16	
13	Check oil level in drum gearbox	16	
15	Check oil level in the drum cartridge	17	
32	Clean the radiators	18	
20, 24	Re-tighten bolted joints	19	Applies only to new or reconditioned component
16	Check rubber elements and screw fasteners	19	
25	Change engine oil and oil filter	19	See engine manual
30	Check battery	20	
	Inspect the air conditioning	20	Optional

Every 500 hours of operation (Every three months)

Item. in fig. 1	Measure	See page	Comments
3	Replace fuel filter		See engine manual
5	Lubricate controls and joints	21	
3	Replace fuel pre-filter	21	
36	Lubricate the steering chain	22	Optional
35	Lubricate the seat bearing	22	Optional

Every 1000 hours of operation (Every six months)

Item. in fig. 1	Measure	See page	Comments
8	Change hydraulic fluid filter	23	
9	Drain condensate from hydraulic reservoir	23	
26	Drain condensate from fuel tank	24	
4	Replace air cleaner main filter	24	
22	Change oil in rear axle differential	24	
23	Change oil in the rear axle planetary gearing	25	
-	Replace the fresh air filter in the cab	25	Optional
	Check diesel engine valve clearance		See engine manual
33	Check belt tension for drive belt system		See engine manual

Every 2000 hours of operation (Yearly)

Item. in fig. 1	Measure	See page	Comments
9, 10	Change fluid in hydraulic reservoir	26	
12, 15	Change oil in the drum cartridge	26	
13	Change oil in drum gearbox	27	
37	Lubricate Forward/Reverse control	27	
	Overhaul air conditioning	28	Optional

EVERY 10 HOURS OF OPERATION (Daily)

Scrapers

– Checking / Adjustment

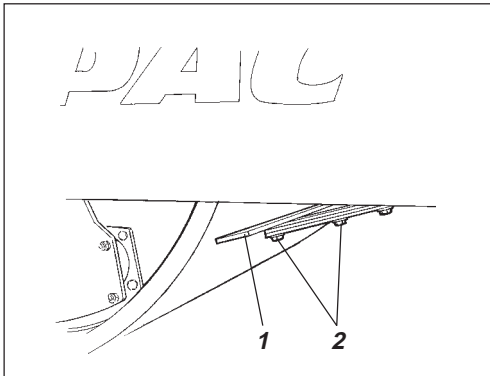

Fig. 2 Scrapers

1. Scraper blade
2. Screws

Loosen the screws (2) and adjust to 20 mm (0.8 in). Tighten the screws. Repeat the procedure on the other scraper.

Soft scrapers (Optional)

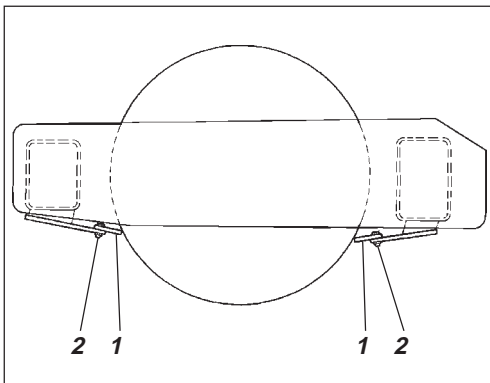

Fig. 3 Scrapers

1. Scraper blade
2. Screws

Loosen the screws (2) and adjust to light contact against the drum. Tighten the screws.

Circulation of air – Inspection

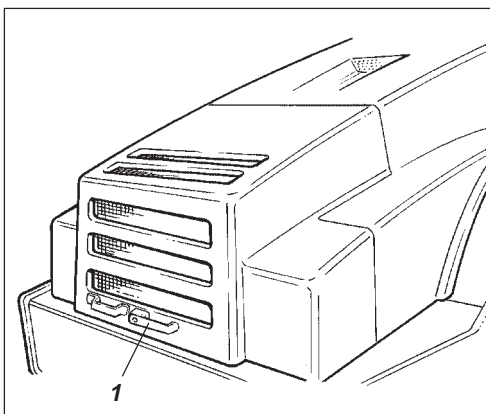

Fig. 4 Cooling vents

1. Hood lock

Ensure that the engine has free circulation of cooling air through the vents in the hood.

To open the engine hood, turn the locking arms upward (1) and raise the hood to its fully open position, checking that the red safety catch on the left gas spring is latched.

WARNING



If the gas-springs of the hood are out of action and the hood is put at its upper position – block the hood so that it cannot fall.

EVERY 10 HOURS OF OPERATION (Daily)

Coolant level – Check

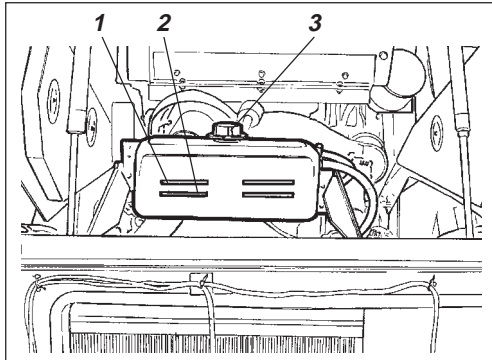

Fig. 5 Radiator

1. Max level
2. Min level
3. Filler cap

Check that level of the coolant is between the max. and min. marks.

WARNING



Danger of scalding. Take great caution if the radiator cap must be opened while the engine is hot. Wear protective gloves and goggles.

Fill with a mixture of 50% water and 50% anti freeze. See page 3 in these instructions and in the engine manual.

CAUTION



Flush the system every other year and change the coolant. Ensure also that air can flow unrestricted through the radiator.

Diesel engine – Check oil level

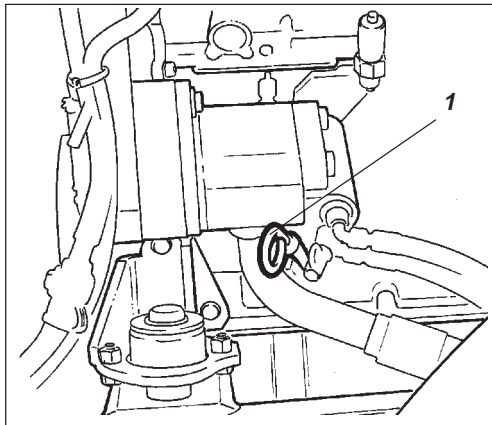

Fig. 6 Engine compartment

1. Oil dipstick

WARNING



Place the roller on a level surface. Switch the engine off and push in the reserve/ parking brake knob for all checking and adjustments on the roller, unless otherwise specified.

WARNING



Danger of burns. Take care not to touch any hot parts of the engine or the radiator when removing the dipstick.

The dipstick is located on the engine's right side.

Pull up the dipstick (1) and check that the oil level is between the upper and lower marks. For further details, refer to the engine manual.

EVERY 10 HOURS OF OPERATION (Daily)

Fuel tank – Filling

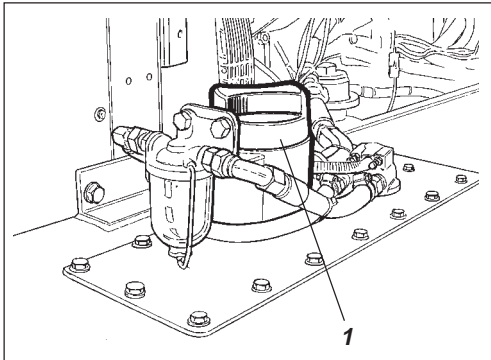

Fig. 7 Fuel tank
1. Filler pipe

Refuel daily with diesel fuel up to the lower edge of the filler pipe (1). Follow the engine manufacturer's specification with regard to the quality of diesel fuel.

WARNING



Switch off the diesel engine. Short-circuit (press) the filler gun against a non-insulated part of the roller before refuelling, and against the filler pipe (1) while refuelling.

WARNING



Never refuel while the engine is running, do not smoke, and avoid spilling fuel.

The fuel tank holds 320 liters (84.5 gal.).

Hydraulic reservoir – Check fluid level

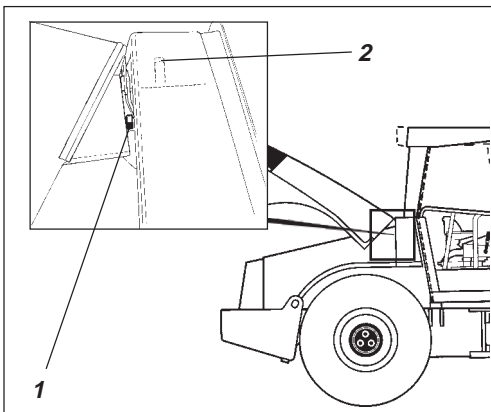

Fig. 8 Hydraulic fluid reservoir
1. Sight glass
2. Filler pipe

Position the roller on a level surface and check that the sight glass reading (1) is between the max. – min. marks. Top off with hydraulic fluid according to the lubricant specification if the level is too low.

Brake function – Check

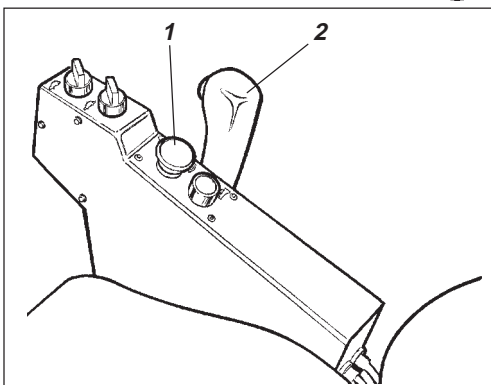

Fig. 9 Control panel
1. Reserve/parking brake knob
2. Forward/reverse lever

WARNING



Check operation of the brakes as follows:

Drive the roller **slowly** forward.

Push the reserve/parking brake knob (1); the warning lamp on the instrument panel should light and the roller should stop.

After testing the brakes, set the forward/reverse lever (2) in neutral.

Pull up the reserve/parking brake knob.

The roller is now ready for operation.

EVERY 50 HOURS OF OPERATION (WEEKLY)

Air cleaner – Check/clean

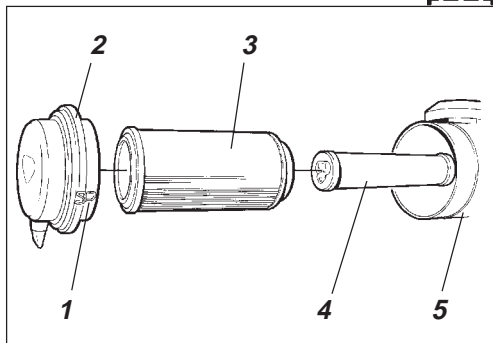

Fig. 10 Air cleaner

1. Locking braces
2. Cover
3. Main filter
4. Backup filter
5. Filter housing

CAUTION



Replace or clean the air cleaner's main filter if the warning lamp on the instrument panel lights up when the diesel engine is operating at full speed.

Undo the three locking braces (1). Then pull off the cover (2) and pull out the main filter (3).

Do not remove the backup filter (4).

Main filter – Cleaning with compressed air

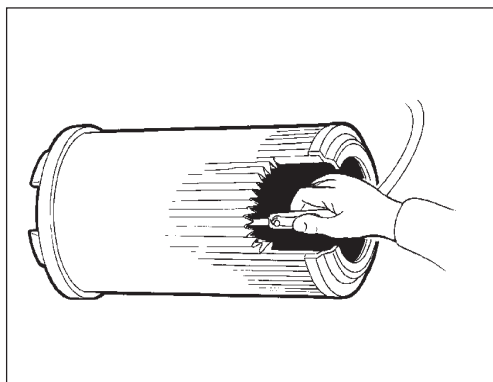

Fig. 11 Main filter

If the main filter is to be cleaned, compressed air at max. 5 bar (72 psi) pressure should be used. Blow up and down along the paper creases on the inside of the filter.

Hold the nozzle at least 2–3 cm (0.8-1.2 in) away from the paper creases so that the paper does not tear under the pressure of air.

WARNING



Use protective goggles when working with compressed air.

Wipe the inside of the cover (2) and filter housing (5).

CAUTION



Check that the hose clamps between the filter housing and inlet hose are tightened and that they do not leak. Check the entire length of the hose all the way to the engine.

CAUTION



Once the main filter has been cleaned a maximum of 5 times, it must be replaced.

Replace the backup filter with a new one at every 5th replacement or cleaning of the main filter. The backup filter cannot be cleaned.

When replacing the backup filter (4), pull out the old filter from its holder, insert a new one and refit the air cleaner in the reverse order to the instructions given in the figure above.

Backup filter – Replacement

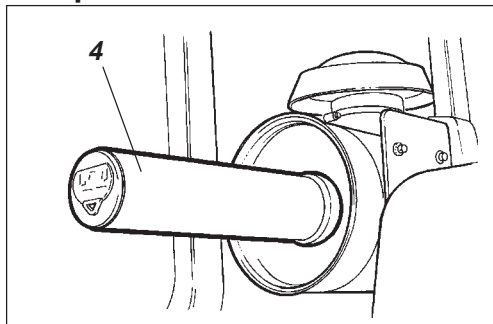

Fig. 12 Air filter

4. Backup filter

EVERY 50 HOURS OF OPERATION (Weekly)

Steering joint/Steering cylinders – Lubrication

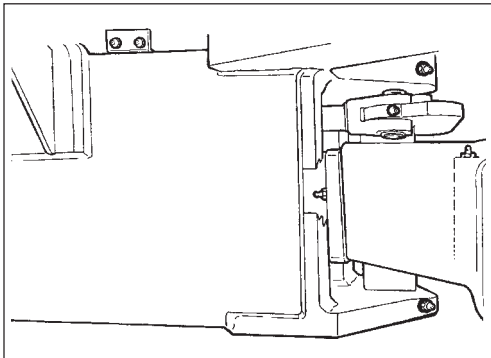

Fig. 13 Steering joint, right side

Steering joint – Lubrication

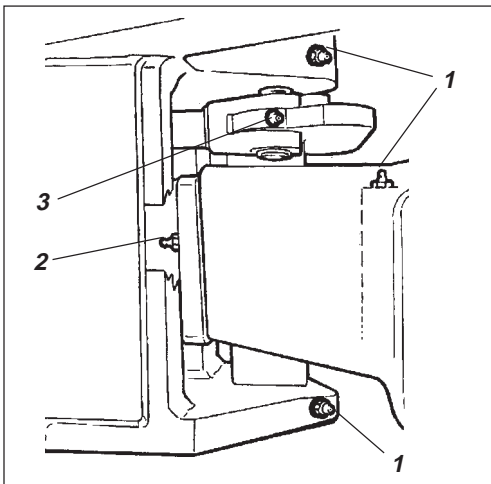

Fig. 14 Steering joint, right side

1. Lubricating nipples, steering joint (x3)
2. Lubricating nipple, steering joint
3. Lubricating nipples, cylinder mount (x1)

Steering cylinder – Lubrication

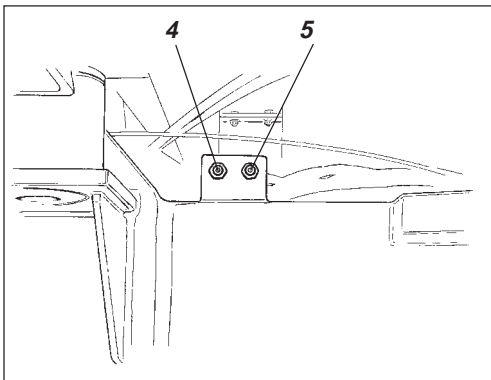

Fig. 15 Steering cylinder, right side

4. Lubricating nipple, rear right steering cylinder mount (x1)
5. Lubricating nipple, rear left steering cylinder mount (x1)

WARNING



Place the roller on a level surface. Switch the engine off and push in the reserve/parking brake knob for all checking and adjustments on the roller, unless otherwise specified.

WARNING



Allow no one to get near the steering joint when the engine is running. Danger of being crushed when steering is operated. Push the reserve/parking brake knob before lubricating.

Turn the steering wheel fully to the left to gain access to all lubricating nipples of the steering system on the right-hand side of the machine (x7).

CAUTION



Use grease as per the lubricant specification.

Wipe off any dirt and grease from the nipples.

Lubricate each nipple (1, 2, and 3) with five strokes of a manual grease gun. Check that grease penetrates through the bearings.

If grease does not penetrate through the bearings, it may be necessary to relieve the load on the articulated joint with a hydraulic jack and then repeat the greasing process.

Wipe all the nipples clean from dirt and grease.

Grease the nipples (4 and 5) with five strokes of the hand grease gun.

Turn the steering wheel fully to the right to gain access to the front lubricating nipple on the left steering cylinder and the lubricating nipple on the bearing bushing. Allow a little grease to remain on the nipples after lubrication, it will prevent dirt from entering.

EVERY 50 HOURS OF OPERATION (Weekly)

Tires – Tire pressure Wheel nuts – Tightening

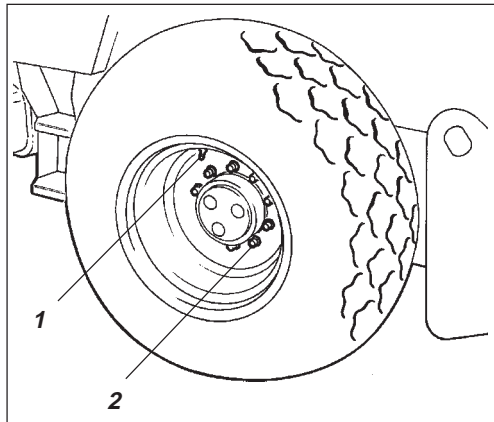

Fig. 16 Wheels
1. Air valve
2. Wheel nut

Check the tire pressures using a pressure gauge.

If the tires are filled with fluid, the air valve (1) must be in the “12 o’clock” position during pumping.

The relevant tire pressures are given under the heading “Specifications”.

Check both tires.

CAUTION



When changing the tires it is important that both of them have the same rolling radius. This is necessary to ensure proper functioning of the anti-slip in the rear axle.

Check the tightening torque of the wheel nuts (2) at 470 Nm (350 lbf.ft). Check both wheels and all the nuts. (Applies only to new machine or recently fitted wheels.)

WARNING



Check the safety manual that accompanies the roller before filling the tires with air.

WARNING



Note: The tires are filled with liquid. This makes the wheels heavier than normal.

WARNING



Never work under the roller with the engine running. Park on a level surface, chock the wheels and press the parking brake control.

Air conditioning (Optional) – Inspection

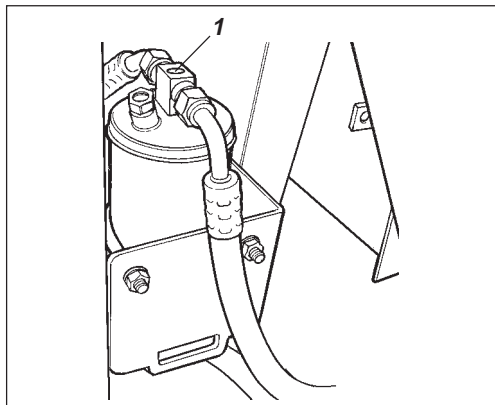

Fig. 17 Drying filter
1. Sight glass

Open the engine hood while the unit is running and look at the sight glass (1) to make sure that no bubbles are visible on the dryer filter. The filter is located on the left side in the front of the engine compartment. If bubbles are visible through the sight glass, it is a sign that the level of refrigerant is too low. If so, stop the unit. There is a risk of damage to the unit if it is run with insufficient refrigerant.

Clean the condenser element (1) free from dust as necessary.

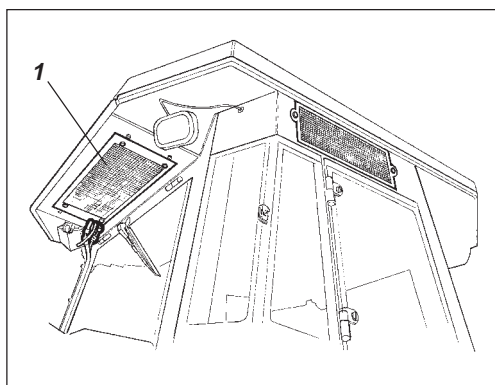

Fig. 18 Cab
1. Condenser element

EVERY 250 HOURS OF OPERATION (Monthly)

Rear axle differential – Check oil level

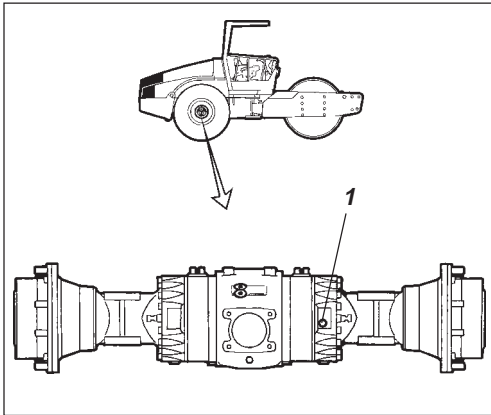

Fig. 19 Oil level check – differential housing
1. Oil level/Filler plug

WARNING



Never work under the roller with the engine running. Park on a level surface. Block the wheels securely.

Wipe clean and remove the level plug (1) and check that the oil level reaches the lower edge of the plug hole. Top off with oil to the right level if the level is low. Use transmission oil according to the lubricant specification.

Rear axle planetary gears – Check oil level

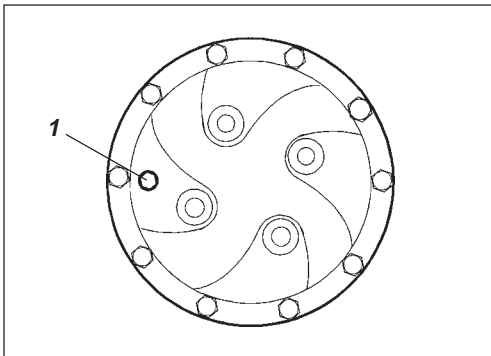

Fig. 20 Oil level check – planetary gear
1. Oil level/Filler plug

Position the roller with the level plug (1) in the planetary gears at 9 o'clock.

Wipe clean and remove the level plug (1) and check that the oil level reaches the lower edge of the plug hole. Top off with oil to the right level if the level is low. Use transmission oil according to the lubricant specification.

Check the oil level in the same way in the rear axle's other planetary gear.

Drum gearbox – Check oil level

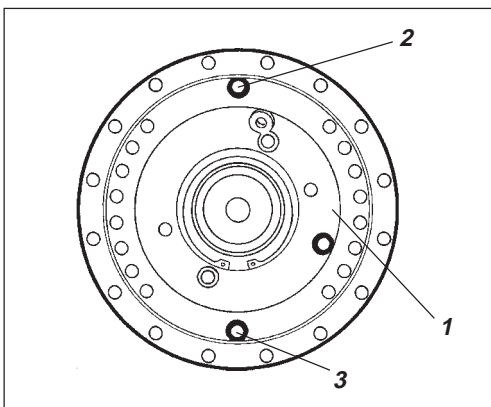

Fig. 21 Oil level check – Drum gearbox
1. Oil level plug
2. Filler plug
3. Drainplug

Position the roller with the level plug (1) at 3 o'clock.

Wipe clean the area around the plug (1) and then undo the plug.

Ensure that the oil level reaches up to the lower edge of the plug hole.

Top off with oil to the right level if the level is low. Use transmission oil according to the lubricant specification.

Clean and screw in the plugs tightly.

EVERY 250 HOURS OF OPERATION (Monthly)

Drum cartridge – Checking the oil level

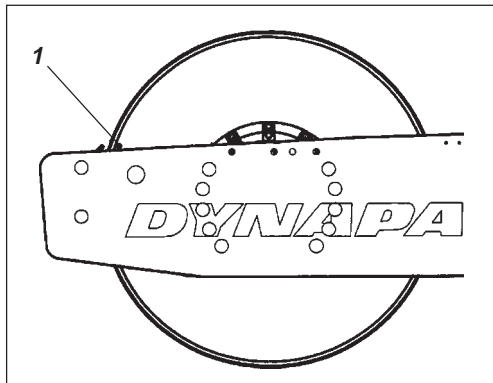

Fig. 22 Left side of drum
1. Indicator pin

Position the machine level so that the indicator pin (1) on the inside of the drum is aligned with the top of the drum frame.

Drum cartridge – Checking the oil level

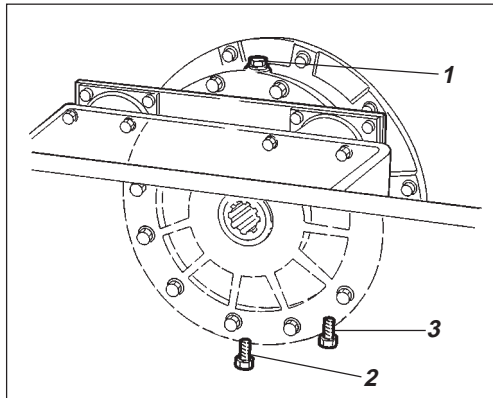

Fig. 23 Roller, right-hand side
1. Filler plug
2. Drain plug
3. Level plug

Wipe the filling plug and level plug clean from dirt.
Unscrew the filling plug (1)

Drum cartridge

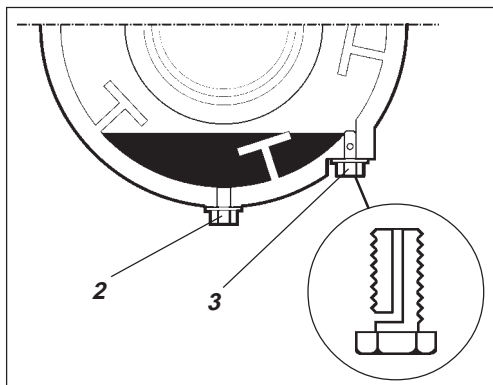

Fig. 24 Drum cartridge
2. Drain plug
3. Level plug

Then unscrew the level plug (3) at the bottom of the cartridge (wrench width 24 mm (0.9 in)) until the hole in the middle of the plug becomes visible.

Top off with oil through the filling plug (1), until oil begins to run out from the level-plug hole. The level is correct when it stops running.

CAUTION



Ensure that only MOBIL SHC 629 is used in the cartridges.

Clean and refit the plugs. Repeat the procedure on the opposite side.

CAUTION



Do not overfill with oil – risk for overheating.

EVERY 250 OPERATING HOURS (Monthly)

Drum cartridge

– Cleaning the ventilation screw

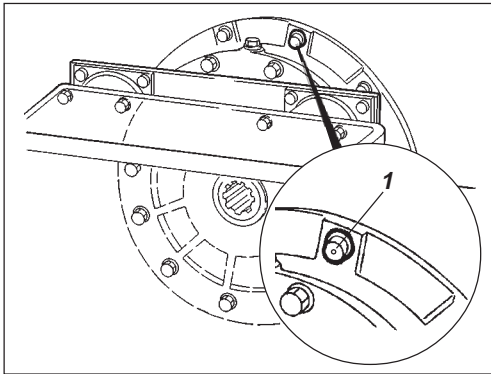

Fig. 25 Drum
1. Ventilated screw

Clean the drum ventilation hole. The hole is required to eliminate excess pressure inside the drum.

Radiator

– Check/clean

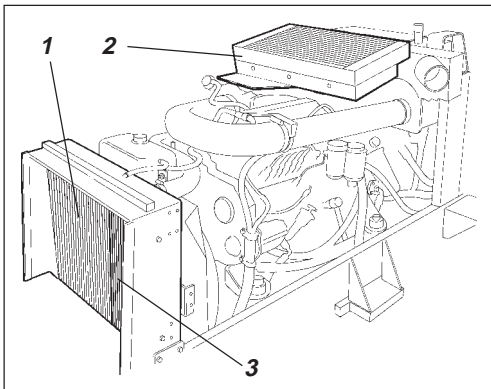

Fig. 26 Engine room
1. Water cooler
2. Hydraulic fluid cooler
3. Intercooler

WARNING



Place the roller on a level surface. Switch the engine off and push in the reserve/parking brake knob for all checking and adjustments on the roller, unless otherwise specified.

Check that air can flow freely through the radiators (1) and (2).

A dirty radiator should be blown clean with compressed air, or alternatively cleaned with a high-pressure washer.

Blow or wash the cooler in the opposite direction to that of the cooling air.

CAUTION



Be careful when using a high-pressure washer – do not place the nozzle too close to the radiator.

WARNING



Use protective goggles when working with compressed air or a high-pressure washer.

EVERY 250 HOURS OF OPERATION (Monthly)

Bolted joints

– Checking tightening torque

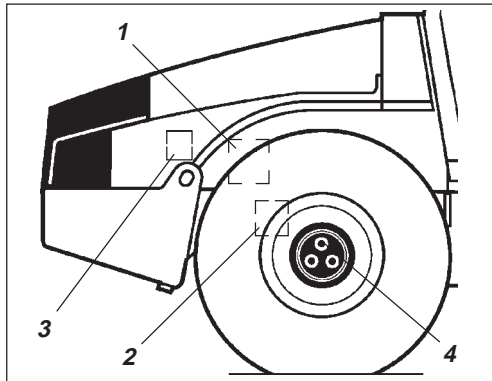

Fig. 27 Right side of machine

1. Steering pump
2. Rear axle
3. Engine suspension
4. Wheel nuts

Rear axle suspension (2) 330 Nm (243 lbf.ft), oiled.

Steering pump against engine (1) 38 Nm (28 lbf.ft).

Engine suspension (3). Check that all M12 bolts (x20) are tightened, 78 Nm (57 lbf.ft).

Wheel nuts (4). Check that all nuts are tightened, 470 Nm (347 lbf.ft), oiled.

(The above applies to new or replaced components only.)

Rubber elements and screw fasteners – Check

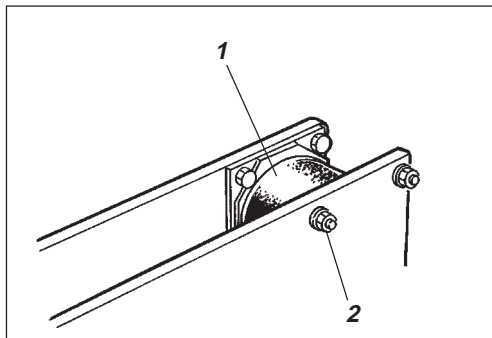

Fig. 28 Roller, vibration side

1. Rubber element
2. Screw fasteners

Check all the rubber elements (1), and replace them all if more than 25% of the elements on the same side of the roller have cracks deeper than 10–15 mm (0.4-0.6 in).

Use a knife blade or other pointed tool when carrying out this check.

Check also that the screw fasteners (2) are tightened.

Diesel engine

– Changing the filter and oil

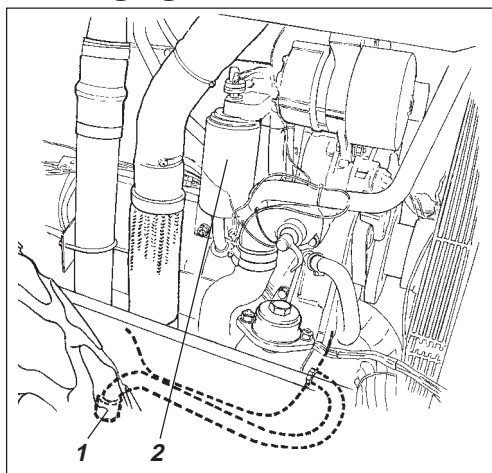

Fig. 29 Left side of engine

1. Drain plug
2. Oil filter

WARNING



Position the roller on a level surface. Stop the engine and apply the parking brake/ reserve brake.

The oil drain plug (1) is most easily accessible from underneath the engine. It is fitted on a tube to the rear axle. Drain the oil when the engine is warm. Place a receptacle for at least 15 litres (16 qts) underneath the drain plug.

WARNING



Danger of being scalded when draining off hot oil. Protect your hands.

Change the engine oil filter (2) at the same time. See also the engine manual.



Dispose of the drained oil and filter in an approved manner.

EVERY 250 HOURS OF OPERATION (Monthly)

Battery

– Check electrolyte level

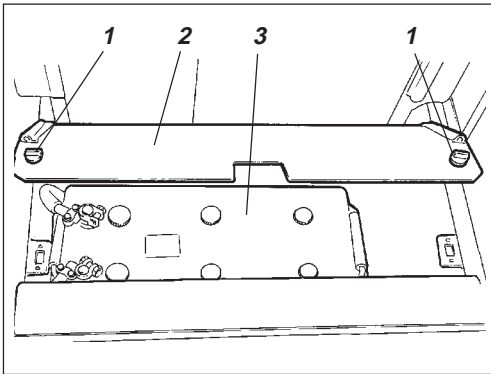

Fig. 30 Battery box

1. Quick-release screws
2. Battery cover
3. Battery

WARNING



Make sure there are no open flame in the vicinity when checking the electrolyte level. An explosive gas is formed in the battery during the charging process.

Lift up the engine compartment cover and undo the quick-release screws (1).

Raise the battery cover (2).

Dry the upper face of the battery.

WARNING



Use protective goggles. The battery contains corrosive acid. In the event of contact, rinse with water.

Battery cell

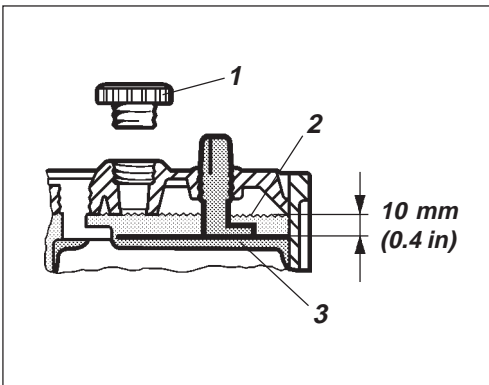

Fig. 31 Electrolyte level in battery

1. Cell cover
2. Electrolyte level
3. Plate

Remove the cell covers and check that the fluid level is about 10 mm (0.4 in) above the plates. Check the level in all the cells. If the level is lower, top up to the correct level with distilled water. If the ambient air temperature is below freezing point, the engine should be run for a while after the distilled water is added, otherwise there is a risk that the water might freeze.

Check that the ventilation holes in the cell covers are not blocked, then refit the covers.

The cable terminals must be properly tightened and clean. Corroded cable connections should be cleaned and greased with alkaline Vaseline.

CAUTION



When disconnecting the battery, always disconnect the negative cable first. When connecting the battery, always connect the positive cable first.



Discard used batteries properly. Batteries contain lead, which is detrimental to the environment.

WARNING



Before doing any electric welding on the machine, disconnect the battery ground cable and then all electrical connections to the alternator.

Air conditioning (Optional)

– Inspection

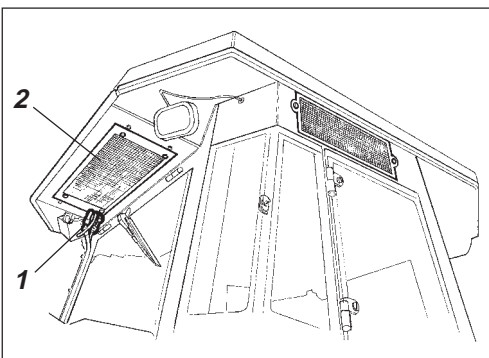

Fig. 32 Air conditioning

1. Refrigerant hoses
2. Condenser element

Inspect refrigerant hoses and connections and make sure that there are no signs of oil film that could indicate leakage of refrigerant.

EVERY 500 HOURS OF OPERATION (Every three months)

Controls and moving joints – Lubrication

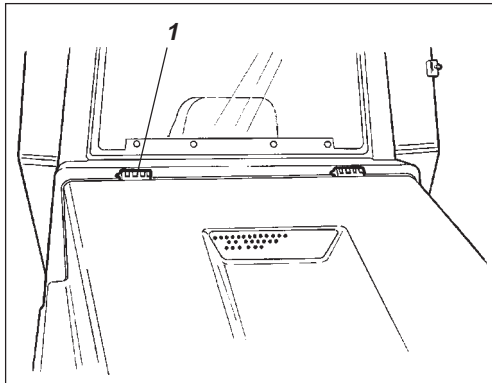

Fig. 33 Enginehood
1. Hinge

Lubricate engine hood hinges (1) and the slide rails of the operator's seat with grease, other joints and controls with oil. Lubricate the cab hinges with grease. See lubricant specification.

Prefilter – Cleaning

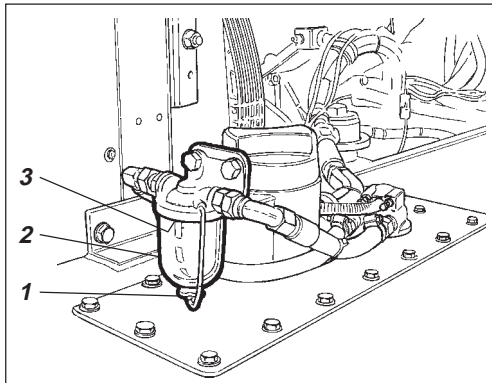

Fig. 34 Engine
1. Screw
2. Glass bowl
3. Strainer

WARNING



Place the roller on a level surface. Switch the engine off and push in the reserve/parking brake knob for all checking and adjustments on the roller, unless otherwise specified.

Loosen the screw (1) and remove the glass bowl (2).

Take out the strainer (3) and clean using a non-flammable fluid. Reinstall the strainer and the bowl.

Start the engine and check that the pre-filter does not leak.

WARNING



Make sure there is adequate ventilation (extraction) if the diesel engine is run indoors. Risk of carbon monoxide poisoning.

EVERY 500 HOURS OF OPERATION (Every three months)

Steering chain and Seat bearing – Lubrication

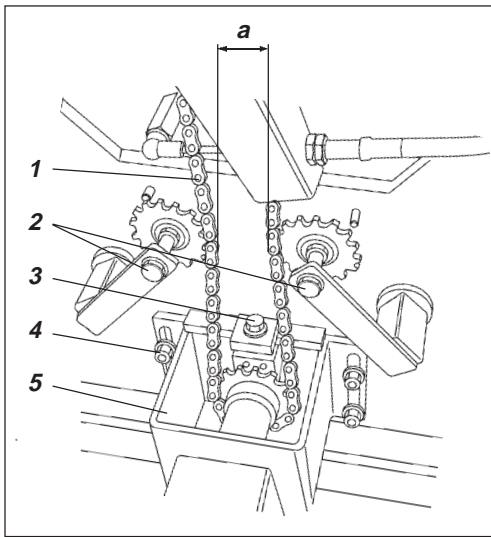

Fig. 35 Underneath operator's position

1. Steering chain
2. Chain-tightening device
3. Adjusting nut
4. Nuts
5. Control valve mount

Optional on rollers without cab

CAUTION



Remember that the chain is a vital part of the steering mechanism.

Clean and lubricate the chain (1) between the seat bearing and steering valve with grease. The chain is accessible underneath the platform.

It is not necessary to remove the chain.

Adjust the chain as follows if it has slackened so that size "a" is less than 30 mm (1.2 in): Loosen the nuts (4) and adjust the mount (5) backwards with the adjusting nut (3) until size "a" is 50 mm (2 in).

Seat bearing – Lubrication

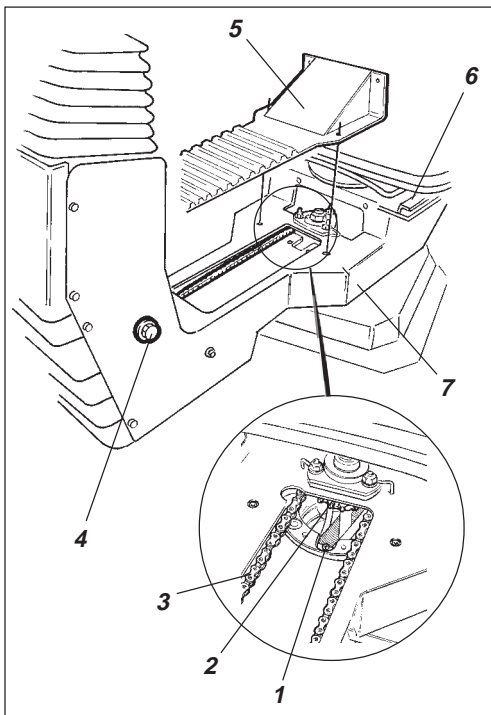

Fig. 36 Seat bearing

1. Lubrication nipple
2. Cogwheel
3. Steering chain
4. Adjusting screw
5. Cover
6. Slide rails
7. Slew interlock

CAUTION



Remember that the chain is a vital part of the steering mechanism.

Remove the cover (5) to gain access to the lubrication nipple (1).

Lubricate the slew bearing of the operator's seat with three strokes of a hand-operated grease gun.

Lubricate the seat locking latch (7), accessible from below.

Also grease the slide rails of the seat (6).

CAUTION



If the seat begins to bind when resetting, it needs to be lubricated more often.

Clean and grease the chain (3) between the seat and the steering column.

If the chain becomes slack on the cogwheel (2), loosen the screws (4) and move the steering column forward, tighten the screws and check the tension of the chain.

EVERY 1000 HOURS OF OPERATION (Every six months)

Hydraulic fluid filter – Change

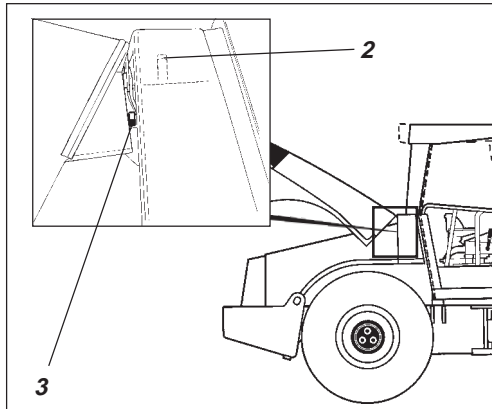

Fig. 37 Hydraulic fluid reservoir
2. Filler cover/bleeder filter
3. Sight glass

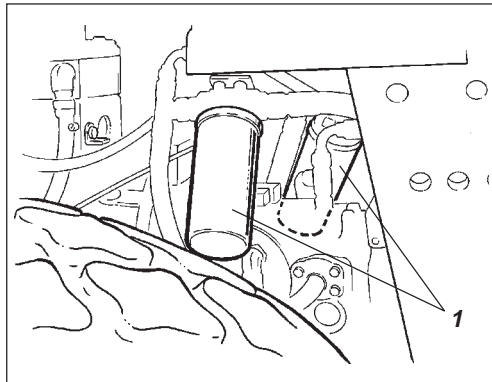

Fig. 38 Engine compartment
1. Hydraulic fluid filters (x2)

Hydraulic reservoir – Drainage

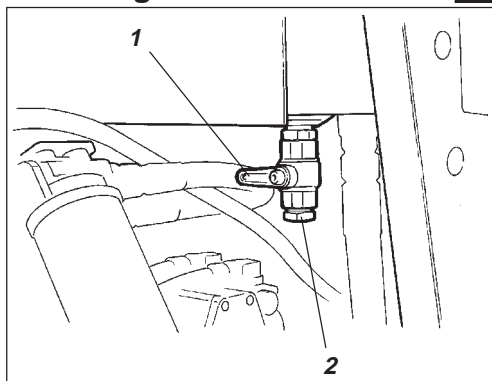

Fig. 39 Hydraulic reservoir, underside
1. Drainage tap
2. Plug

WARNING



Place the roller on a level surface. Switch the engine off and push in the reserve/parking brake knob for all checking and adjustments on the roller, unless otherwise specified.

Undo the cover/bleeder filter (2) on top of the reservoir so that over-pressure inside the reservoir can be eliminated.

Check that the bleeder filter (2) is not blocked – air should flow freely through the cover in both directions.

If there is a blockage in either direction, clean the filter with a little diesel oil and blow through with compressed air until the blockage disappears, or replace the cover with a new one.

WARNING



Always use protective goggles when working with compressed air.

Clean thoroughly around the oil filters.



Remove the oil filters (1) and dispose of them in an approved manner. They are **single-use** filters and cannot be cleaned.

CAUTION



Check that the old sealing rings do not remain stuck on the filter holders, otherwise this might give rise to oil leakage between the old and new seals.

Clean the filter holder sealing surfaces thoroughly.

Apply a thin film of hydraulic fluid on the seals of the new filter. Screw on the filter by hand.

CAUTION



First tighten the filter until its seal is in contact with the filter attachment. Then turn an additional half revolution. Do not over-tighten the filter as this might damage the seal.

Start the engine and ensure that there is no leakage of hydraulic fluid from the filters. Check level of fluid in the sight glass (3) and top up as required.

WARNING



Make sure there is adequate ventilation (extraction) if the diesel engine is run in-doors. Risk of carbon monoxide poisoning

Condensate in the hydraulic reservoir is removed via the drainage tap (1).

Drainage should be performed when the roller has been standing for a long period of time, for example overnight. Drain as follows:

Remove the plug (2).

Place a container under the tap.

Open the tap (1) and let any trapped condensate run out.

Shut the drainage tap.

Refit the plug.

EVERY 1000 HOURS OF OPERATION (EVERY SIX MONTHS)

Fuel tank – Drainage

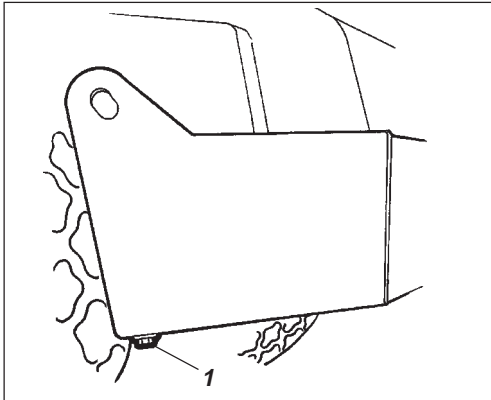

Fig. 40 Fuel tank
1. Drainage plug

Water and sediment in the fuel tank are removed via the drainage plug in the bottom of the fuel tank.

CAUTION



Be very careful during draining. Do not drop the plug or else all the fuel will flow out.

Drainage should be performed when the roller has been standing for a long period of time, for example overnight. The fuel level should be as low as possible.

The roller should preferably have been standing with this side somewhat lower, so that water and sediment will gather near the drainage plug (1). Drain as follows:

Place a container under the plug (1).

Undo the plug and drain off the water and sediment until only clean diesel fuel appears through the plug opening. Refit the plug.

Replace the main filter (3) of the air cleaner even if it has not yet been cleaned five times, see under 50 hours for filter replacement.

CAUTION



If a clogged filter is not replaced the exhaust fumes will be black and the engine will lose power. There will also be danger of severe damage to the engine.

Air filter – Replacement

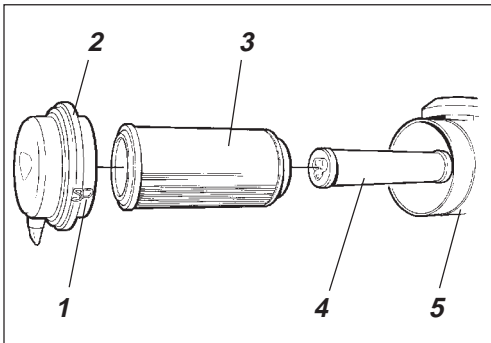

Fig. 41 Air cleaner
1. Locking braces
2. Cover
3. Main filter
4. Backup filter
5. Filter housing

Rear axle differential – Oil change

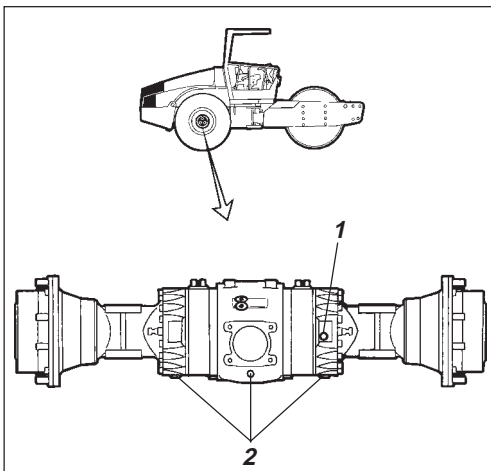

Fig. 42 Rear axle
1. Oil level/Filler plug
2. Drainage plugs

WARNING



Never work under the roller with the engine running. Park on a level surface and block the wheels securely.

Wipe clean and remove the level/filler plug (1) and all three drain plugs (2) and drain the oil into a suitable receptacle. The volume is almost 12 litres (12.7 qts).



Save the oil and deposit it in an approved manner.

Refit the drainage plugs and top up with fresh oil until the correct level is reached.

Note: It takes a while for the oil to flow into the axle. Do not fill the entire volume all at once.

Refit the oil-level/filler plug. Use transmission oil, see the lubrication specification.

EVERY 1000 HOURS OF OPERATION (Every six months)

Rear axle planetary gears – Oil change

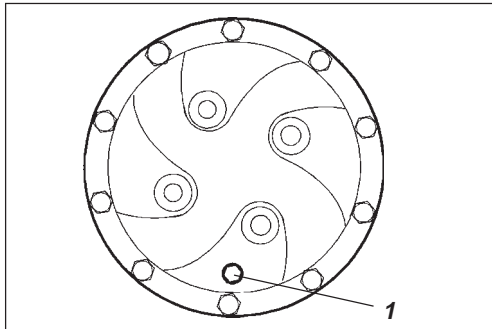

Fig. 43 Planetary gear/drainage position
1. Plug

Position the roller with the plug (1) at its lowest position.

Wipe clean, unscrew the plug (1) and drain the oil into a suitable receptacle. The volume is about 2 litres (2.1 qts).



Save the oil and deposit it in an approved manner.

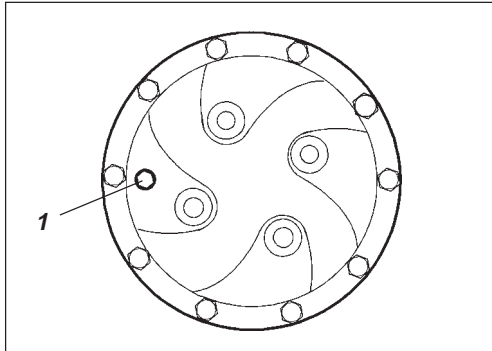

Fig. 44 Planetary gear/filling position
1. Plug

Position the roller with the plug at 9 o'clock.

Fill with oil to lower edge of level hole.

Refit the plug and repeat the process on the other side. Use transmission oil. See the lubrication specification.

Fresh air filter – Replacement

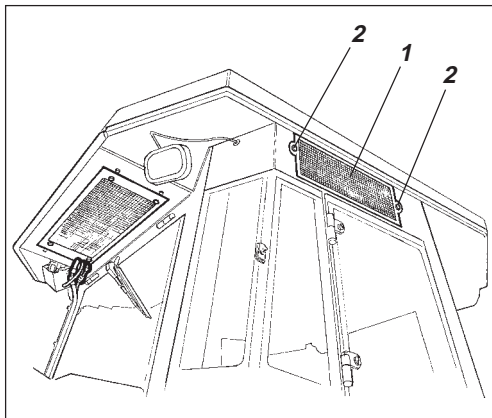

Fig. 45 Cab
1. Fresh air filter
2. Screw (x2)

Loosen the two screws (2) at the rear of the cab roof. Take down the whole holder and remove the filter insert.

Replace with a new filter.

It may be necessary to replace the filter more often if the machine is used in a dusty environment.

EVERY 2000 HOURS OF OPERATION (Yearly)

Hydraulic reservoir – Fluid change

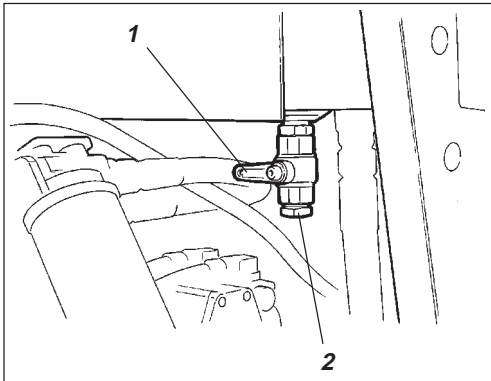

Fig. 46 Hydraulic reservoir, underside

- 1 Drainage tap
- 2. Plug

WARNING



Place the roller on a level surface. Switch the engine off and push in the reserve/parking brake knob for all checking and adjustments on the roller, unless otherwise specified.

WARNING



Danger of being burned when draining hot oil. Protect your hands.

Obtain a container for collecting the used fluid. The container should have a volume of at least 60 litres (16 gal).

A suitable container may be an empty oil drum or similar item which is placed beside the roller. The fluid then runs in a hose from the drainage plug (1) to the oil drum, after the plug (2) has been removed and the tap opened.



Save the oil and deposit it in an approved manner.

Fill up with fresh hydraulic fluid as per the instructions under the heading "Hydraulic reservoir – Check fluid level".

Replace the hydraulic fluid filters at the same time.

Start the diesel engine and operate the various hydraulic functions.

WARNING



Make sure there is adequate ventilation (extraction) if the diesel engine is run indoors.
(Risk of carbon monoxide poisoning)

Check the fluid level and top up if necessary.

Position the machine level so that the indicator pin (1) on the inside of the drum is aligned with the top of the drum frame.

Drum cartridge – Oil change

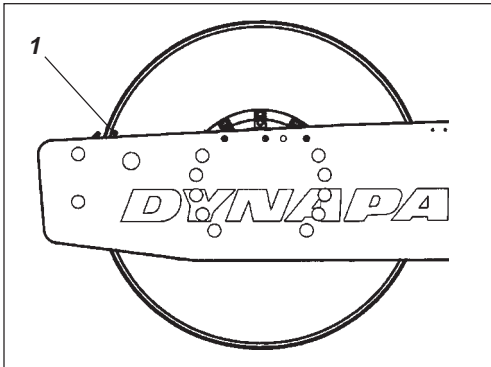

Fig. 47 Left side of drum

- 1. Indicator pin

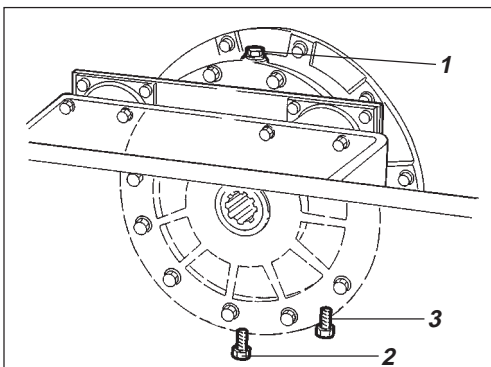

Fig. 48 Right side of the drum

- 1. Filler plug
- 2. Drain plug
- 3. Level plug

Place a receptacle for about 5 litres (5.3 qts) underneath the level/drain plug (2).



Save the oil and deposit it in an approved manner.

Clean and unscrew the filler plug (1) and the drain plug (2). Allow all of the oil to drain off. Fit the drain plug, and fill with fresh synthetic oil according to the instructions under the "Drum cartridge-checking the oil level" heading, page 17.

Repeat the procedure on the opposite side.

CAUTION



Ensure that only MOBIL SHC 629 is used in the cartridges.

EVERY 2000 HOURS OF OPERATION (Yearly)

Drum gearbox – Changing the oil

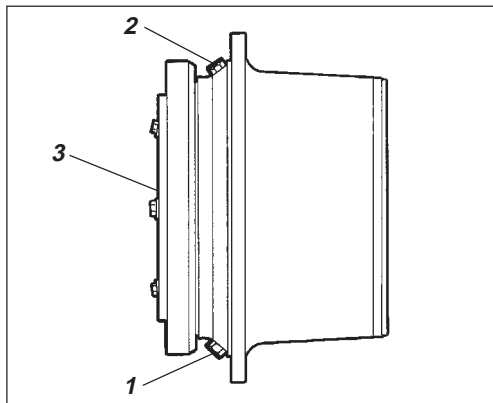

Fig. 49 Drum gearbox
1. Drain plug
2. Filler plug
3. Level plug

Place the roller on a level surface with the plugs (1) and (2) as illustrated.

Wipe clean, unscrew the plugs (1, 2 and 3) and drain the oil into a suitable receptacle, capacity about 3.5 liters (3.7 qts).

Refit the plug (1) and fill with oil up to the level plug (3), according to “Drum gearbox – Checking the oil level” (see page 16).

Use transmission oil, see Lubricant Specification.

Clean and refit the level plug (3) and filler plug (2).

Forward/Reverse lever – Lubrication

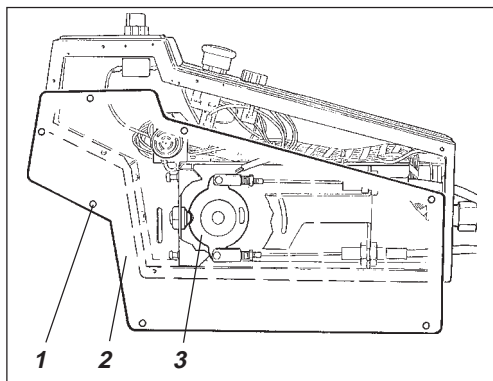

Fig. 50 Forward/Reverse lever
1. Screw
2. Plate
3. Cam disk

Unscrew the screws (1) and remove the plate (2).

Grease the contact surface of the cam disc (3).

Refit the plate (2) with the screws (1).

Steering joint – Check

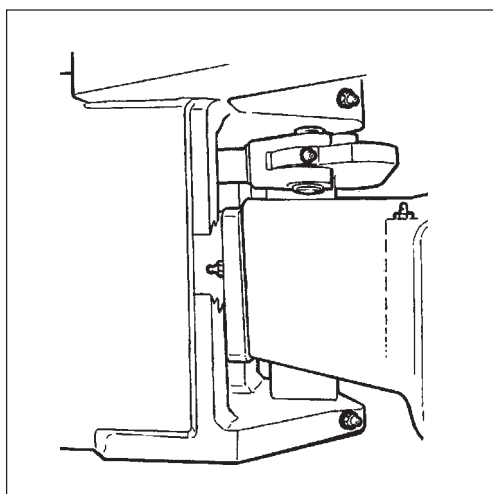

Fig. 51 Steering joint

Inspect the steering joint to detect any damage or cracks.

Check and correct any loose bolts.

Check also for any stiffness and play.

EVERY 2000 OPERATING HOURS (Yearly)

Air conditioning (Optional) – Overhaul

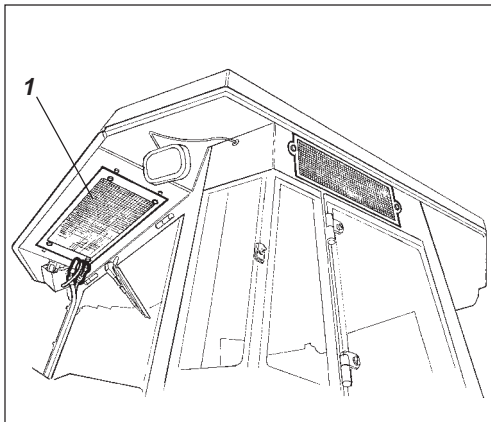

Fig. 52 Cab
1. Condenser element

Regular inspection and maintenance are necessary to ensure satisfactory long-term operation.

Clean the condenser element (1) free from dust with the aid of compressed air. Blow from above.

CAUTION



The air jet could damage the flanges of the elements if it is too powerful.

WARNING



Wear protective goggles when working with compressed air.

Inspect the fastening of the condenser element.

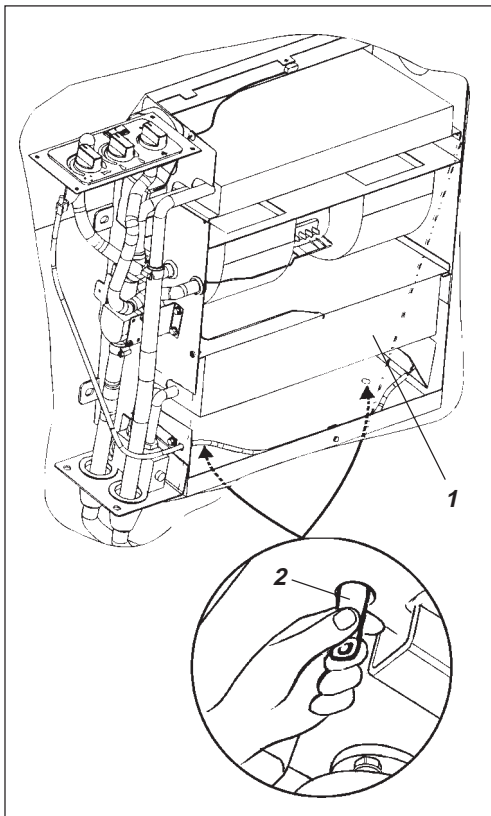

Fig. 53 Aircondition
1. Cooling element
2. Drain valve (x2)

Clean the cooler unit and the cooling elements (1) free from dust with the aid of compressed air.

Inspect the system hoses for chafing. Make sure that drainage from the cooling unit is unobstructed so that condensation does not accumulate inside the unit.

Drain by pressing the valves (2) that are located under the cab.

EVERY 2000 OPERATING HOURS (Yearly)

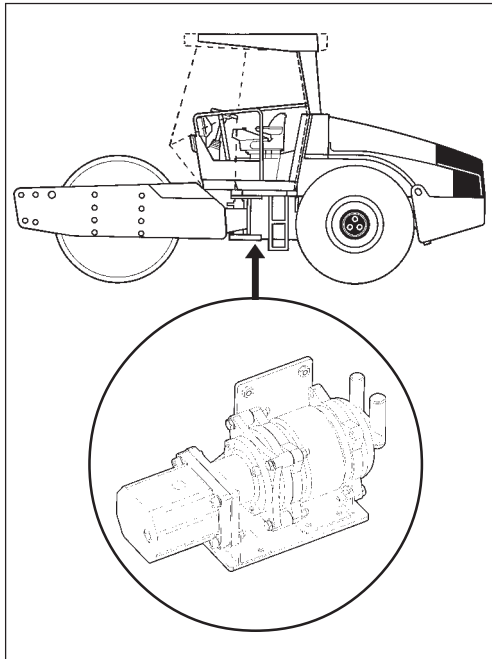

Fig. 54 Compressor

Inspect the compressor and hydraulic motor fastenings.

The unit should be run at least five minutes every week, if possible, to ensure lubrication of rubber gaskets in the system.

CAUTION



The air unit should not be run when the outdoor temperature is below 0°C (32°F).

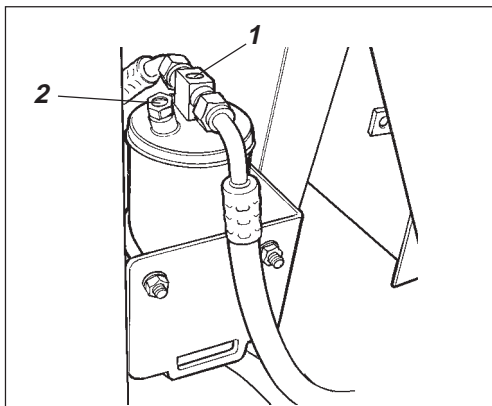

Fig. 55 Drying filter in engine compartment
1. Sight glass
2. Moisture indicator

WARNING



Never work under the roller with the engine running. Park on a level surface, chock the wheels and press the parking brake control.

Open the engine hood while the unit is operating and check in the sight glass (1) that no bubbles are visible on the dryer filter. If bubbles are visible through the sight glass, it is a sign that the level of refrigerant is too low. If so, stop the unit. There is a risk of damage to the unit if it is run with insufficient refrigerant.

Check the moisture indicator (2). The color should be blue; if it is beige the dryer cartridge must be replaced by an authorized service company.

WARNING



The compressor will be damaged if the unit is run with too little refrigerant.

WARNING



Do not disconnect the hose coupling.

WARNING



The cooling system is pressurized. Incorrect handling can result in serious personal injuries.

WARNING



The system contains pressurized refrigerant. Releasing refrigerants into the air is prohibited. The refrigerant circuit may only be repaired by an authorized company.

LONG-TERM STORAGE

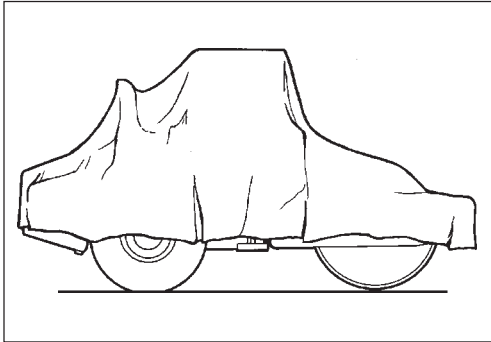

Fig. 56 Protecting the roller from the elements

CAUTION



For long-term storage (longer than one month), the following instructions should be followed.

These instructions apply for storage lasting up to 6 months.

Before re-commissioning the roller, the points marked with an asterisk * must be restored.

Diesel engine

- * See the manufacturer's instructions in the engine instruction manual, which is supplied together with the roller.

Battery

- * Remove the battery from the roller, clean its exterior, check its electrolyte level and recharge it once a month.

Air cleaner, exhaust pipe

- * Cover the air cleaner or its opening with plastic or tape, and cover also the exhaust pipe's opening. This is done so as to prevent moisture from penetrating into the engine.

Fuel tank

Fill the fuel tank completely to prevent condensation.

Hydraulic reservoir

Drain off any condensation water and fill the hydraulic reservoir to the upper mark.

Steering cylinder, hinges etc.

Lubricate the steering joint bearings and the steering cylinder's two bearings with grease.

Grease the steering cylinder's piston with conservation grease.

Grease also the engine compartment cover's hinges, the seat slide rails, the engine-speed control and the forward/reverse control mechanism.

Tires (All-weather)

Check that tire pressure is 110 kPa (1,1 kp/cm²), (16 psi).

Covers, tarpaulin

- * Place the instrument cover on the steering column. Cover the entire machine with a tarpaulin, which should hang some way off the ground. If possible, store the roller indoors, preferably in a building with a uniform temperature.

SPECIAL INSTRUCTIONS

Standard lubricants and other recommended oils

Upon delivery from the factory, the various systems and components are filled with the oils specified see lubricant specification and they can be used at ambient temperatures from -10°C to +40°C (14°F - 104°F).

CAUTION



A maximum temperature of +35°C (95°F) applies for biological hydraulic fluid.

Higher ambient temperature max. +50°C (122°F)

When operating in hotter ambient temperatures, but up to max. +50°C (122°F), the following instructions apply:

The diesel engine can handle this temperature with the standard oil, but the following oils must be used in the other components:

Hydraulic system with mineral fluid: Shell Tellus TX100 or corresponding.

Other components using transmission oil: Shell Spirax HD 85W/140 or corresponding.

Temperatures

The temperature limits apply for a roller with standard features.

Rollers with extra equipment such as noise suppressers etc. may require additional attention at the upper temperatures.

High-pressure washing

CAUTION



When washing the machine, do not direct the jet of water directly at the fuel or hydraulic fluid tank covers. This is particularly important when using a high-pressure washing unit.

Do not spray water directly on electric components or the instrument panel. Put a plastic bag over the filler cap of the fuel tank and secure with a rubber band. This will prevent water from entering the venting hole in the filler cap. This could otherwise cause operational disturbance, for example, a clogged filter.

Extinguishing fires

If there is a fire in or on the machine, it is best to use an ABE-class fire extinguisher. However, a BE-class CO₂ extinguisher is also suitable.

ROPS, protective cab

If the roller is equipped with a protective structure (ROPS, Roll Over Protective Structure), or protective cab, never subject the structure or cab to welding or drilling. Never attempt to repair a damaged structure or cab; they must be replaced with new ones.

Starting assistance

When an auxiliary starter battery is used, always connect the positive terminal on the auxiliary battery to the positive terminal on the roller's battery, and negative to negative.

ELECTRICAL SYSTEM, FUSES

Fuses and relays

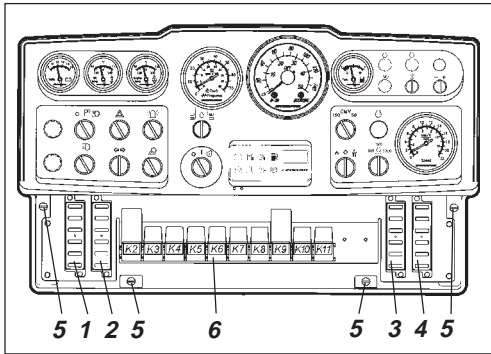

Fig. 57 Instrument panel

- 1,2,3,4. Fuse boxes
5. Quick-screws
6. Relays

The electrical regulating and control system is protected against overload by 27 fuses and 12 relays. The number depends on how much extra equipment is fitted on the machine.

The four fuse boxes (1,2,3,4) and the relays are located behind the lower instrument plate, which can be removed by turning the four quick-screws (5) a ¼-turn.

The machine is equipped with a 12 V electrical system and an alternator.

WARNING



Connect the battery to the correct polarity (- to ground). The cable between battery and alternator must not be disconnected when the engine is running.

Fuses on the machine

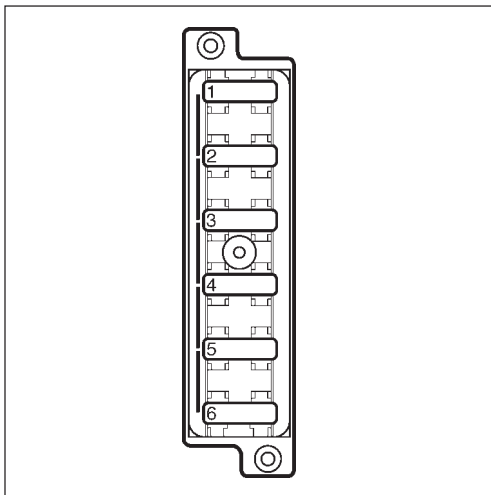

Fig. 58 Fuse box, left side (1)

- 7,5A 1. Brake valve, starter relay, hourmeter
7,5A 2. VBS relay
7,5A 3. Indicating panel
7,5A 4. Horn
7,5A 5. Low/High speed/Strike-off blade □
3A 6. Reversing alarm □

Fuse box, left side (2)

- 7,5A 1. Instrumentation
3A 2. Compaction meter □
7,5A 3. Hazard beacon □
7,5A 4. Anti-spin □
20A 5. Air cond. □
20A 6. Air cond. □

□ = Optional

The figure shows the rating and function of the different fuses.

All fuses are flat pin fuses.

The tachograph and memory for the radio are protected at the battery master disconnect switch by a 0,5A and 3A fuse, respectively.

Fuse box, right side (3)

- 20A 1. Working lights, left □
20A 2. Working lights, right, instrument illumination □
7,5A 3. Headlight, left □
7,5A 4. Headlight, right, instrument illumination* □
5. -
6. -

Fuse box, right side (4)

- 10A 1. Hazard beacon □
10A 2. Direction indicators, main fuse □
7,5A 3. Position light, left, front and rear □
5A 4. Position light, right, front and rear □
5A 5. Direction indicator, left, front, rear and side □
5A 6. Direction indicator, right, front, rear and side □

* When driving lights are fitted

ELECTRICAL SYSTEM, FUSES

Fuses in the cab

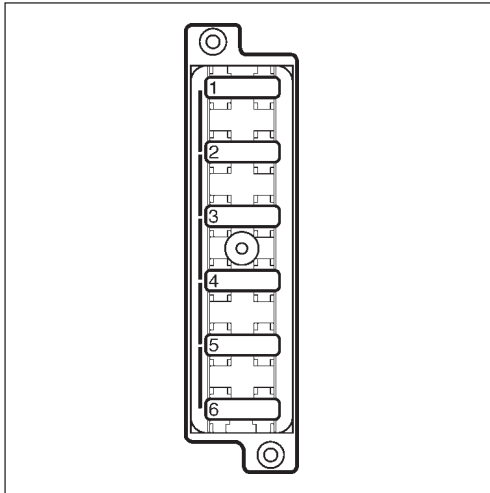

Fig. 59 Fuse box overhead in cab

- 20A 1. Rear cab spotlight
- 10A 2. Front cab spotlight, radio
- 5A 3. Cab interior lighting
- 25A 4. Heater/fresh air fan
- 10A 5. Rear screen wiper/screen-wash
- 10A 6. Front screen wiper/screen-wash

The electric system in the cab is equipped with its own fuse box, located overhead at the front right part of the cab.

The figure shows the ampere rating and function of the different fuses. All fuses are of the flat pin type.

Main fuses

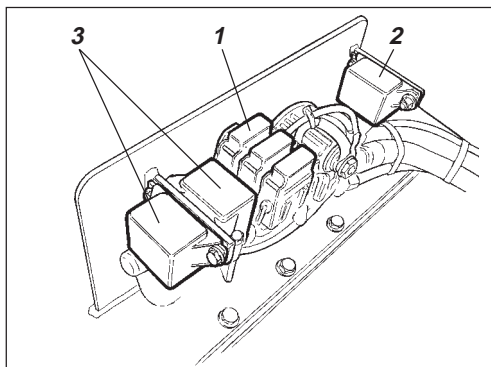

Engine compartment *Motorum*

- 1. Main fuses
- 2. Fuel solenoid relay
- 3. Starter relay

There are four main fuses (1). These are located behind the battery master disconnect switch. The three screws need to be unscrewed to remove the plastic cover.

The fuses (1) are of the flat pin type.

- Supply, machine 30 A (Green)
- Supply, cab 50 A (Red) □
- Supply, lighting 40 A (Orange) □
- Supply, Aircondition 30 A (Green) □

The start relay (2) and the preheating relays (3) for the engine are also fitted here.

Relays

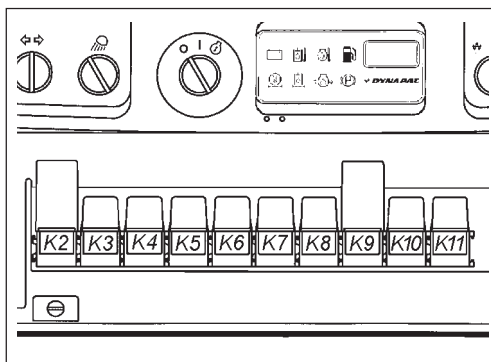

- K2 VBS relay
- K3 Main relay
- K4 Horn relay
- K5 Hourmeter relay
- K6 Fuel level relay
- K7 Reverse alarm relay □
- K8 Lights relay □
- K9 Direction indicator relay □
- K10 Brakes relay
- K11 Air cond. relay □

□ = Optional

Fig. 61 Instrument panel

ELECTRICAL SYSTEM, FUSES

Fuses at the battery disconnecter

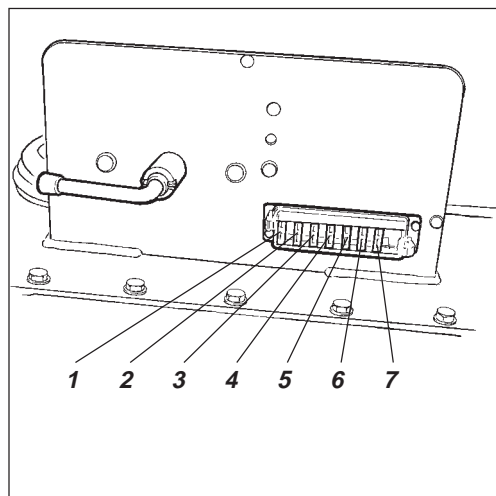

Fig. 62 Fuse box in engine compartment

- 5A 1. QSB engine (ignition)
- 5A 2. Diagnostic lamps, engine
- 7.5A 3. ECM electronic
- 7.5A 4. ECM electronic
- 7.5A 5. ECM electronic
- 10A 6. Fuel pump
- 10A 7. Fuel pump
- 8. Vacant

