

DYNAPAC CA150 OPERATION

O150EN3

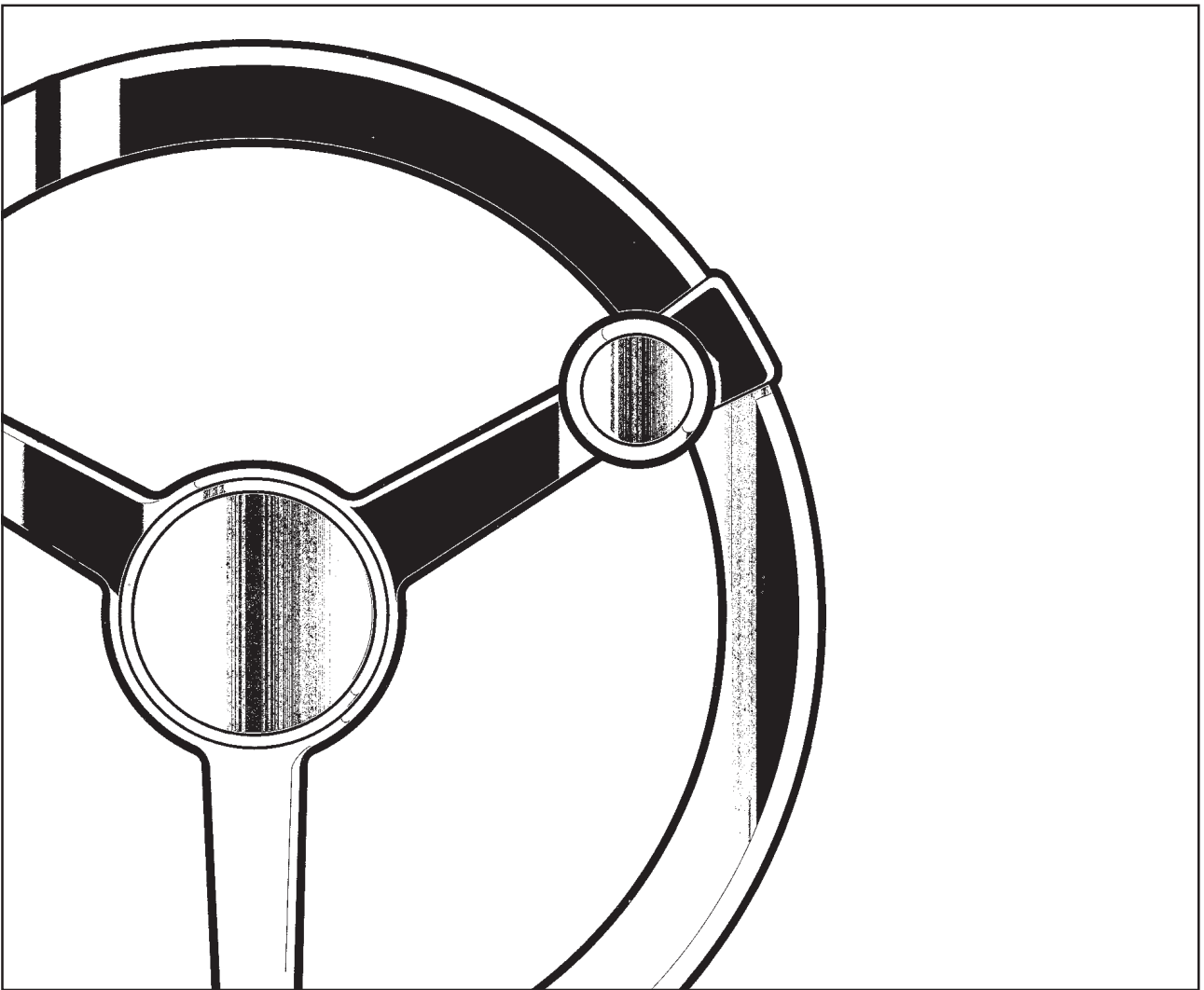

DYNAPAC
Metso Dynapac AB

Box 504, SE-371 23 Karlskrona, Sweden
Phone: +46 455 30 60 00, Fax: +46 455 30 60 30
www.dynapac.com

DYNAPAC

Vibratory Roller CA150

Operation O150EN3, February 2004

**Diesel engine:
CA 150: Cummins 4BT 3.3**

**These instructions apply from:
CA150 PIN (S/N) *73X20400***

**KEEP THIS MANUAL FOR
FUTURE REFERENCE**

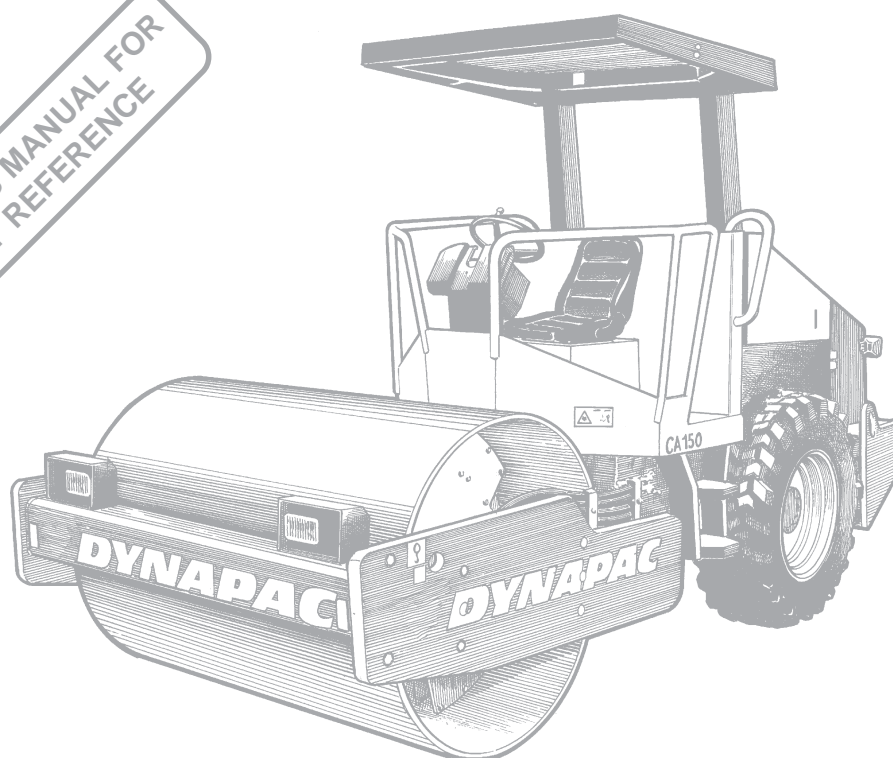

CA150 is Dynapac's light vibratory soil compactor. Available in STD, D (smooth drum) and P, PD (padfoot) versions. The P, PD version has its widest range of application on cohesive material and rockfill materials.

All types of supporting and reinforcement courses can be compacted, and the interchangeable drums, ie, D to PD and vice versa, give enhanced versatility in the choice of application.

The cab and safety-related accessories are described in this manual. Other accessories, such as the compaction meter, etc. are described in separate instructions.

CONTENTS

	Page
Safety instructions (Read the Safety Manual also)	3
Safety when driving	4
Safety decals, location/description	5, 6
Machine and engine plates	7
Instruments and controls	8
Instruments and controls, functional description	9, 10
Controls in the cab	11
Before starting	13-15
Starting	16
Operation	17
Driving/Vibration	18
Braking	19
Parking	20
Lifting	21
Towing	22
Instructions for towing	23
Towing/Retrieval	24
Transport	24
Operating instructions - Summary	25

WARNING SYMBOLS

WARNING



Safety instructions – Personal safety

CAUTION



Special caution – Machine or component damage

SAFETY MANUAL

WARNING



The safety manual, which accompanies each machine, must be studied by each operator of the roller. Always follow the safety rules and do not remove the manual from the roller.

GENERAL

This manual contains instructions concerning operation and use of the roller. For information regarding care and maintenance, see the manual, "MAINTENANCE, CA150".

WARNING



When starting up and driving a cold machine, which implies cold hydraulic fluid, the braking distance will be longer than normal until the machine reaches normal working temperature.

CALIFORNIA

Proposition 65 Warning

Diesel engine exhaust and some of its constituents are known to the State of California to cause cancer, birth defects, and other reproductive harm.

SAFETY INSTRUCTIONS (Read the Safety Manual also)



1. The operator must be familiar with the contents of the OPERATION MANUAL before starting the roller.
2. Make sure that all instructions in the MAINTENANCE MANUAL are followed.
3. Only trained and/or experienced operators may drive the roller. Passengers are not allowed on the roller. Remain seated during all operation.
4. Never use the roller if it is in need of adjustment or repairs.
5. Board and leave the roller only when it is stationary. Use the grips and railings that are provided. Always use a "three-point grip" - both feet and one hand or one foot and both hands - when boarding or exiting the machine.
6. The ROPS (Roll Over Protective Structure) should always be used when the machine is operated on risky ground.
7. Drive slowly in sharp bends.
8. Avoid driving at an angle on slopes; drive straight up or down.
9. When driving close to unsafe edges or holes, make sure that at least two thirds of the drum width is firmly on material that has already been compacted.
10. Make sure that there are no obstacles in the direction of travel, on the ground or overhead.
11. Drive extra carefully on uneven ground.
12. Use the safety equipment provided. The seat belt must be worn on machines fitted with ROPS.
13. Keep the roller clean. Clean dirt and grease from the operator's platform without delay. Keep all signs and decals clean and clearly legible.
14. Safety measures before refueling:
 - Stop the engine.
 - Do not smoke.
 - No naked flame in the vicinity.
 - Ground the nozzle of the filling device against the tank to prevent sparks.
15. Before repairs or service:
 - Place chocks against the drums/wheels and against the strike-off blade.
 - Lock the articulation if required.
16. Hearing protectors are recommended if the noise level exceeds 85 dB(A). The noise level may vary depending on what material the machine is operating on.
17. Make no changes or modifications on the roller that could affect safety. Changes may only be made following written consent by Dynapac.
18. Avoid using the roller before the hydraulic fluid has reached its normal working temperature. Remember that the braking distance will be longer if the fluid is cold. See starting instructions in the OPERATION MANUAL.

SAFETY WHEN DRIVING

Driving near an edge

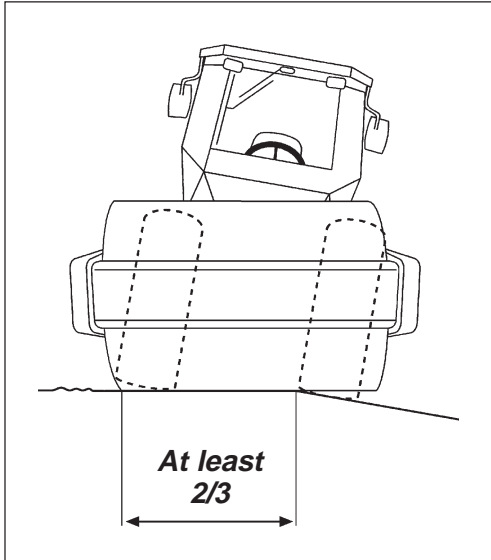

Fig. 1 Position of drum when driving near an edge

When you drive near an edge, at least two thirds of the drum width must be on solid ground.



Remember that the machine's center of gravity is displaced outward when you steer to one side. For example, it shifts to the right when you steer to the left.

Slopes

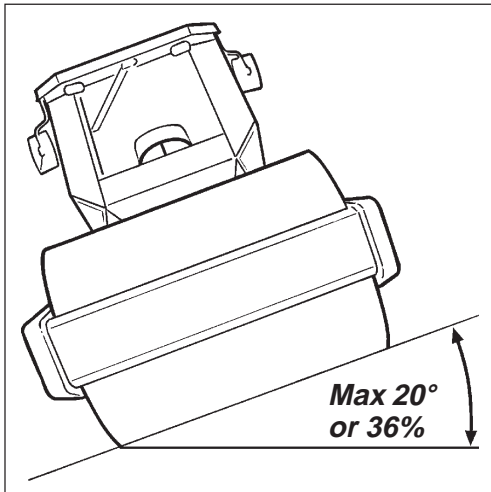

Fig. 2 Tipping angle on side slopes



The ROPS (Roll Over Protective Structure) is always recommended when driving on slopes or insecure ground.



Where possible, avoid all driving across a slope. Instead, drive up and down on sloping ground.

The tilting angle is measured on a hard, level surface with the machine stationary, steering angle zero, vibration switched OFF and all tanks full. Remember that loose ground, steering of the machine, vibration switched ON, driving speed and raising the center of gravity (for example, with accessories) may cause the machine to topple even on a smaller slope than that stated here.



To leave the cab in an emergency, release the hammer located on the rear right post and break the rear window.

SAFETY DECALS, LOCATION/DESCRIPTION

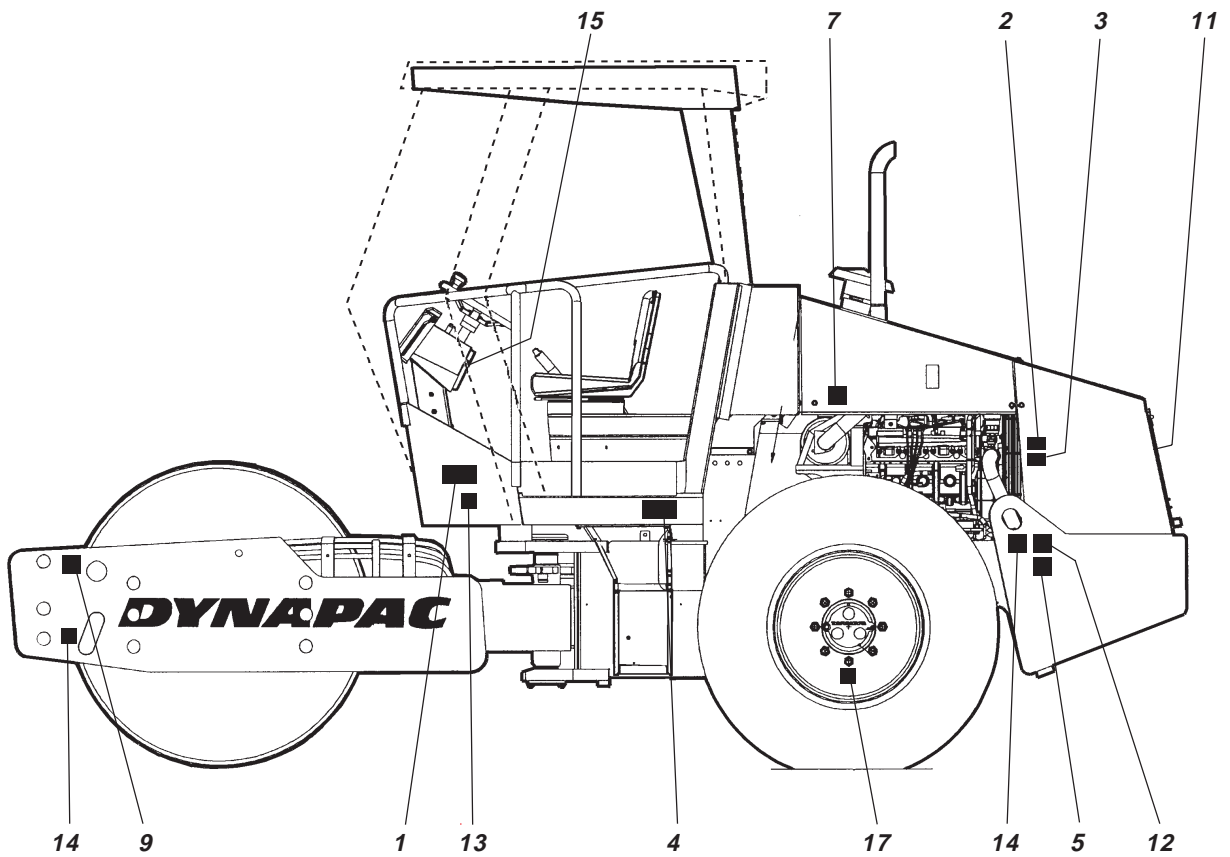
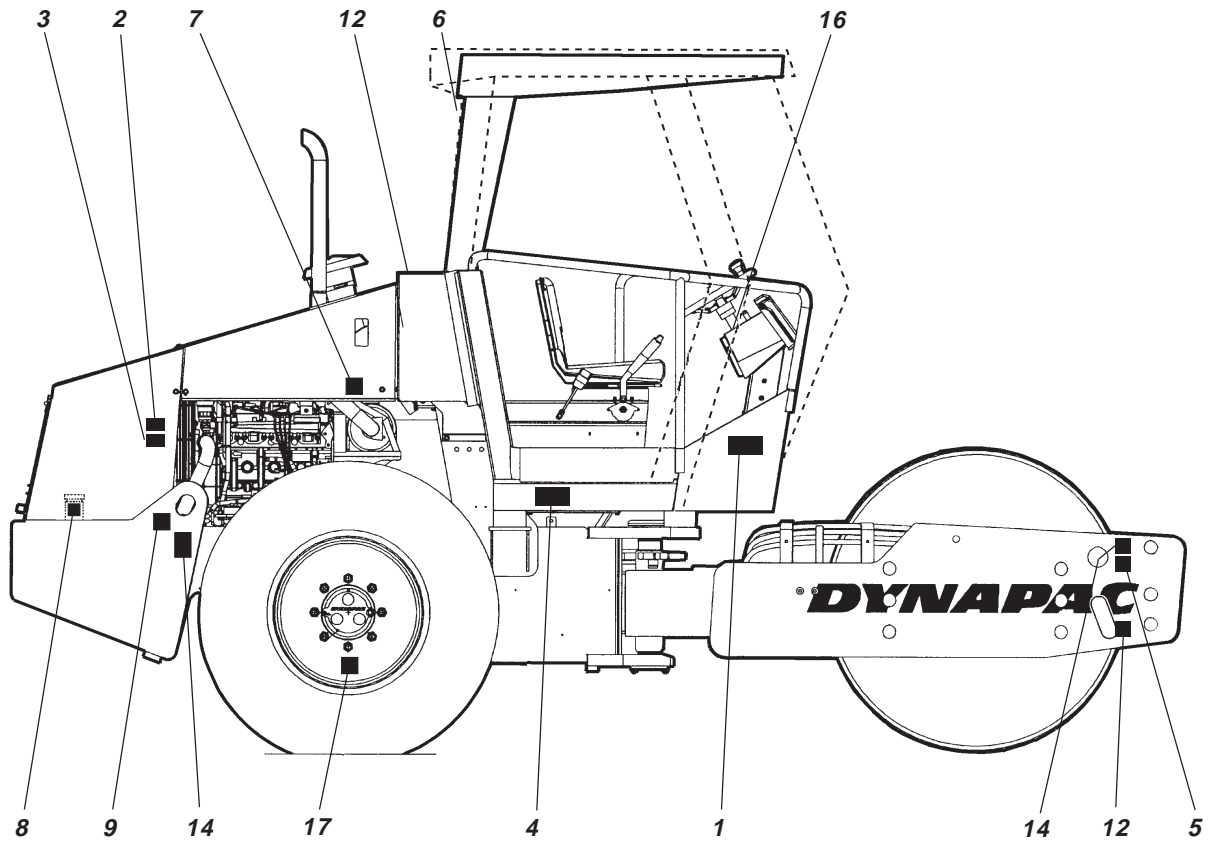

SAFETY DECALS, LOCATION/DESCRIPTION



1. Crush zone, articulation/ Drum. Maintain a safe distance from the crush zone.



4. The operator is urgently requested to read the safety manual, and the operation and maintenance instructions before using the machine.

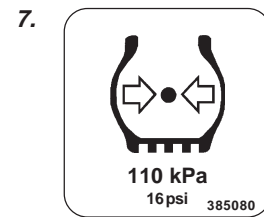

7. Tire pressure



2. Warning - rotating engine components. Keep your hands at a safe distance from the danger zone.



5. The articulation must be interlocked when lifting. Read the instruction manual.



8. Diesel fuel

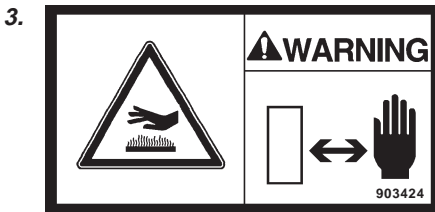

3. Warning - hot surfaces in the engine compartment. Do not touch.



6. Emergency exit

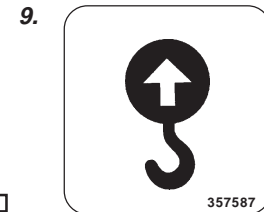

9. Lifting point

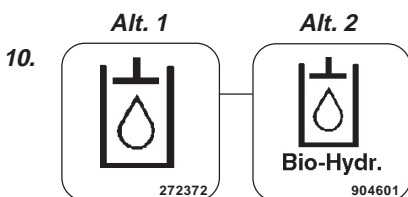

Hydraulic fluid

Biological hydraulic fluid

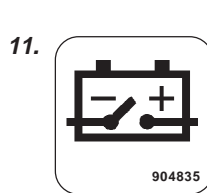

11. Battery disconnect

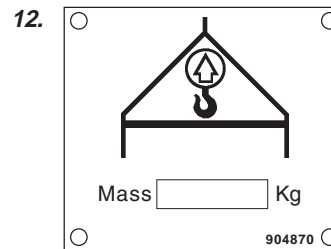

12. Lifting plate

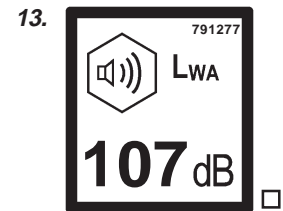

13. Sound Power level



14. Securing point

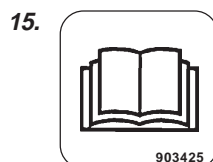

15. Handbook compartment



17. Tires filled with ballast (Optional). Read the instruction manual.



□ = Optional

MACHINE AND ENGINE PLATES

Machine plate

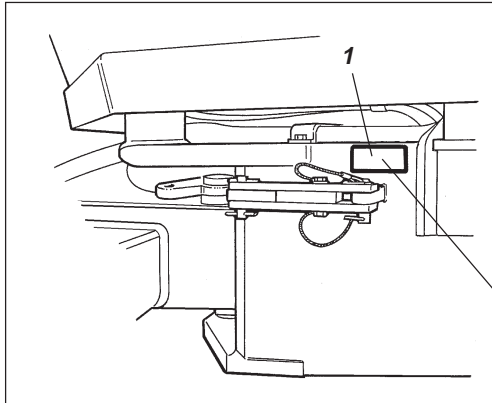
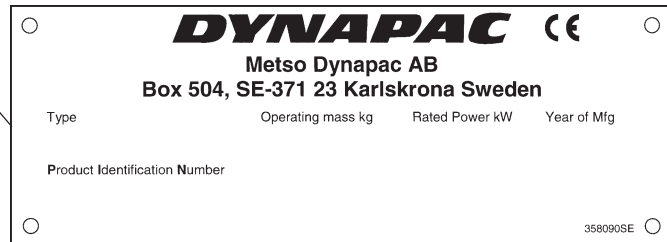

Fig. 3 Operator's platform
1. Machine plate

The machine plate (1) is affixed on the front left side of the frame, by the steering joint. The plate shows the manufacturer's name and address, type of machine, product identification number (PIN), weight in working order, engine power and year of manufacture (the year of manufacture is not specified if the machine is delivered outside the EU).

Please state the roller PIN when ordering spares.



PIN on frame

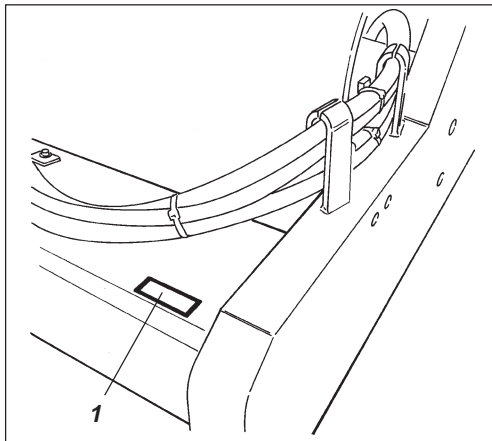

Fig. 4 Front frame
1. PIN

The PIN (1) of the machine is punched on the front right edge of the forward frame beam.

Engine plate

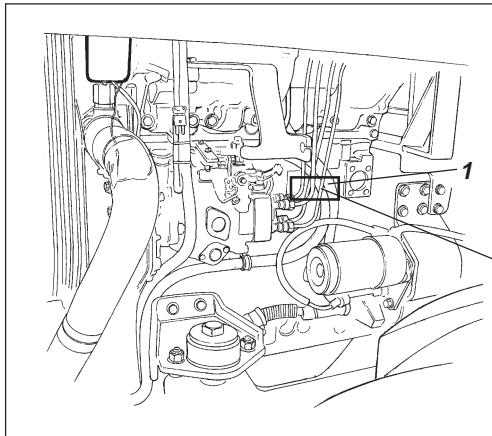

Fig. 5 Engine
1. Engine/EPA sign

The engine plate (1) is affixed to the right side of the engine under the injection pump. The plate indicates the type of engine, serial number and engine data. Please state the engine serial number when ordering spares. See also the Engine Manual.

Cummins Engine Company, Inc Columbus, Indiana USA 47202-3005 www.Cummins.com WARNING: Injury may result and warranty is voided if fuel rate, rpm or altitude exceed published maximum values for this model and application. This engine conforms to YYYY U.S. EPA and California regulations for large non-road compression ignition engines as applicable. This engine is certified to operate on diesel fuel.	Important Engine Information	
	Model B3.3 ESN68006012	
Gross rated HP/kW	80 /60 at 2200 rpm	
Low Idle RPM	800 RPM	
Fuel Rating	FR30004	
CPL	2674	
Displacement:	3.261 L/199 in ³	
Timing-BTDC	8 degrees	
Valve Lash Intake	0.014in/0.35mm	
(cold engine) Exhaust	0.020in/0.50mm	
Fuel rate at rated HP/kW	61mm ³ /st	
S.O.	SO94678	
Made in Japan	6204-81-2411	
EPA Cert. Family:	ICEXL03.3AAB	
European Approval Number:	e11*97/68CA*00/000*0069*00	
Date of Manufacture	yyyy-mm-dd	

INSTRUMENTS AND CONTROLS

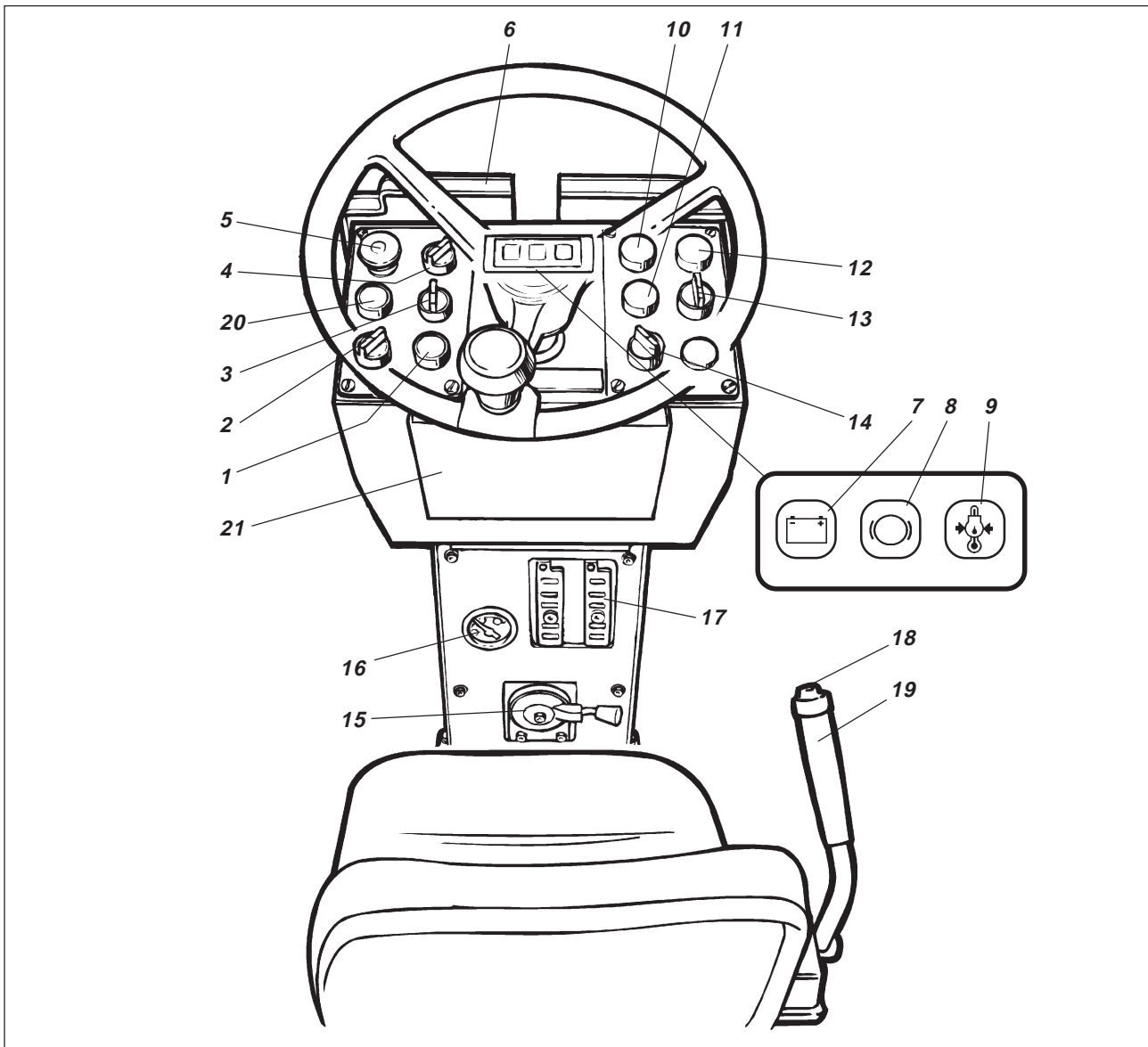





















Fig. 6 Instruments and control panel

- | | |
|---|--|
| 1. Horn | 12. Warning lamp, hydraulic temperature |
| 2. Starter switch | 13. Amplitude selector Low/0/High |
| 3. Hazard beacon <input type="checkbox"/> | 14. Speed selector, rear axle <input type="checkbox"/> |
| 4. Working lights <input type="checkbox"/> | 15. Engine revs control |
| 5. Reserve/parking brake knob | 16. Fuel gauge |
| 6. Instrument protection | 17. Fuse box |
| 7. Warning lamp, charging | 18. Vibration ON/OFF |
| 8. Brake warning lamp | 19. Forward/Reverse lever |
| 9. Warning lamp, engine oil pressure/Engine temperature | 20. Test button for warning lamps |
| 10. Warning lamp, hydraulic filter | 21. Handbook compartment |
| 11. Warning lamp, air filter | |
- = Optional

INSTRUMENTS AND CONTROLS, FUNCTIONAL DESCRIPTION

Items in fig. 6	Designation	Symbol	Function
1	Horn, switch		Press to sound the horn.
2	Starter switch		<p>In position  the electric circuit is broken.</p> <p>In position  all instruments and electric controls are powered.</p> <p>In position  the start motor is activated.</p>
3	Hazard beacon, switch (Optional)		Turn right to switch on the hazard beacon.
4	Working lights, switch (Optional)		Turn right to switch on the working lights.
5	Reserve brake/Parking brake		<p>Press to activate the reserve brake. Press when the machine is stationary to activate the parking brake.</p> <p>Pull out to release both brakes.</p>
6	Instrument protection	—	Fold down over the instruments to protect from weather and damage.
7	Warning lamp, battery charging		If this lamp lights while the engine is running, the alternator is not charging. Stop the engine and remedy the fault.
8	Brake warning lamp		The lamp lights when the parking or reserve brake knob is pushed in and the brakes are applied.
9	Warning lamp, oil pressure		The lamp lights if engine oil pressure is too low. Stop the engine immediately and locate the fault.
10	Warning lamp, hydraulic filter		If this lamp lights while the engine is running at full rev, the hydraulic filters must be changed.
11	Warning lamp, air filter		If this lamp lights while the engine is running at full rev, the air cleaner must be cleaned or replaced.
12	Warning lamp, hydraulic temperature		If this lamp lights, the hydraulic fluid is too hot. Do not drive the roller; cool the fluid by allowing the engine to idle and locate the fault.

INSTRUMENTS AND CONTROLS, FUNCTIONAL DESCRIPTION

Items in fig. 6	Designation	Symbol	Function
13	Amplitude selector		The left mode gives low amplitude. The right mode gives high amplitude. Vibration is OFF in the O mode.
14	Speed selector, rear axle (Optional)		Transportation speed (High) Working speed (Low)
15	Revs control, diesel engine	—	Working revs in the upper position. Idling in the lower position.
16	Fuel gauge		Indicates fuel tank level.
17	Fuse box	—	Contains fuses for the electrical system.
18	Vibration ON/OFF, switch		Press once and release to switch vibration ON, press again to switch vibration OFF. The above applies only when the amplitude selector (13) is in the High or Low mode.
19	Forward/Reverse lever	—	The lever must be in neutral to start the engine, it cannot be started with the forward/reverse lever in any other position. Direction of travel and speed of the roller is regulated with the forward/reverse lever. The roller moves forward when the lever is moved forward, etc. Speed of the roller is regulated in proportion to how far the lever is moved from neutral. The further from neutral, the higher the speed.
20	Test button for warning lamps		The lamps 10, 11, 12 are checked when the switch is pressed.
21	Handbook compartment		Stowage space for safety manual and operator's manuals.

CONTROLS IN THE CAB

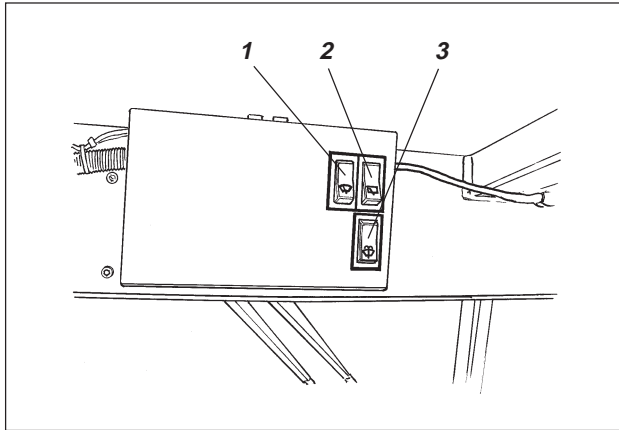

Fig. 7a Cab roof, front

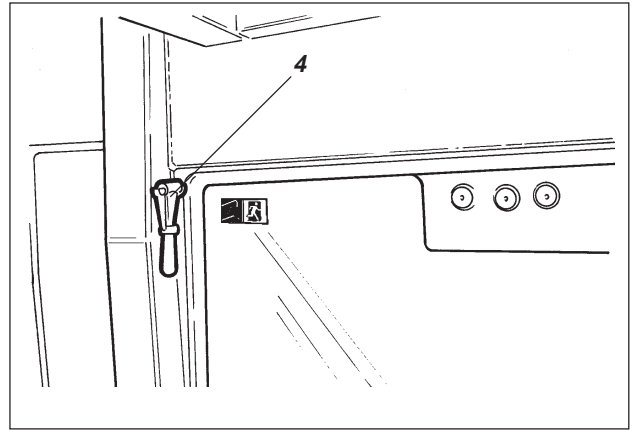

Fig. 7b Cab roof, rear

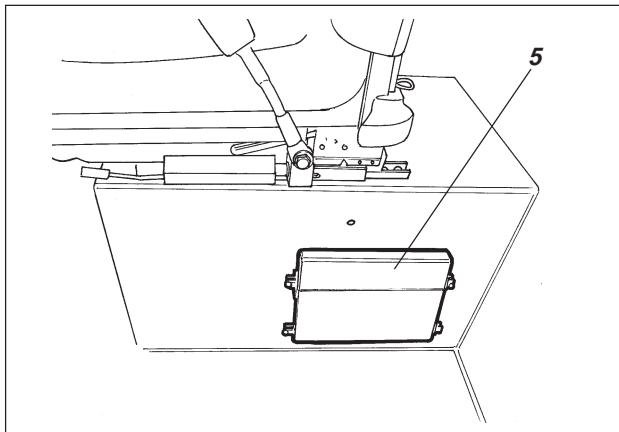

Fig. 7c Cab, left side

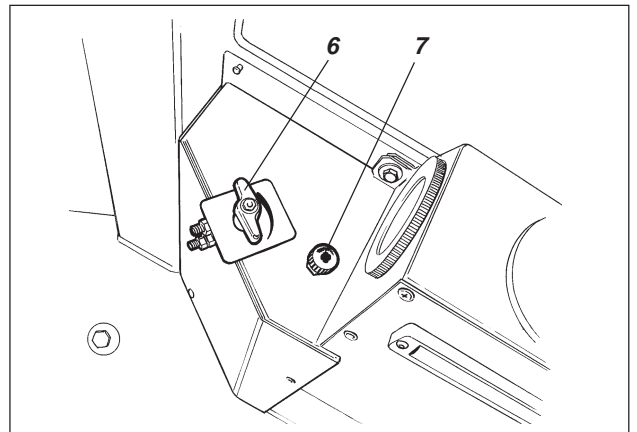

Fig. 7d Cab, right side

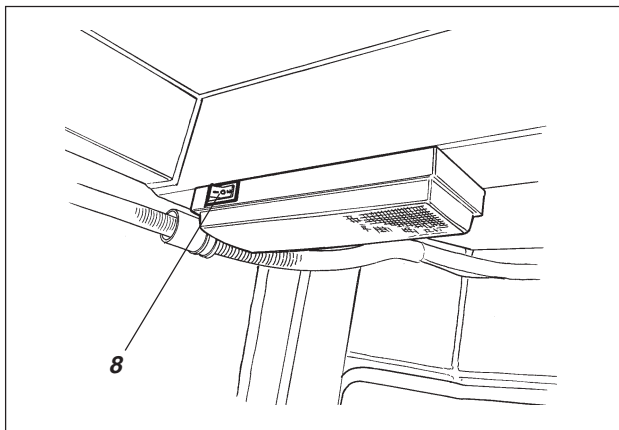

Fig. 7e Cab, rear

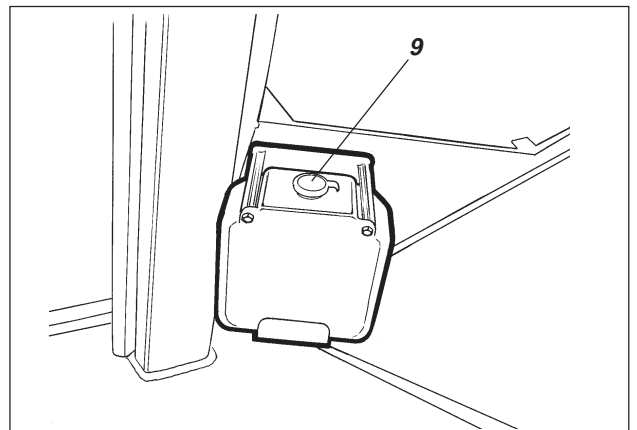











Fig. 7f Cab, left side

CONTROLS IN THE CAB, FUNCTIONAL DESCRIPTION

Items in fig. 7	Designation	Symbol	Function
1	Wiper front, switch		Press to turn on the front wiper.
2	Wiper rear, switch		Press to turn on the rear wiper.
3	Screenwash front and rear panes, switch		Press at the top to spray the windscreen. Press at the bottom to spray the rear screen.
4	Hammer for emergency evacuation		To evacuate the cab in an emergency, release the hammer and break the REAR window.
5	Handbook compartment		Stowage space for safety manual and operator's manuals.
6	Heater (Optional)		Left mode, maximum heating. Right mode, heating turned off.
7	Air fan, switch (Optional)		Left mode, fan turned off. Right mode, cab ventilation increases in three steps.
8	Cab lighting, switch		Press to turn on the cab lights.
9	Windshield washer fluid		Fill with new fluid as needed.

BEFORE STARTING

Battery disconnecter – Switching ON

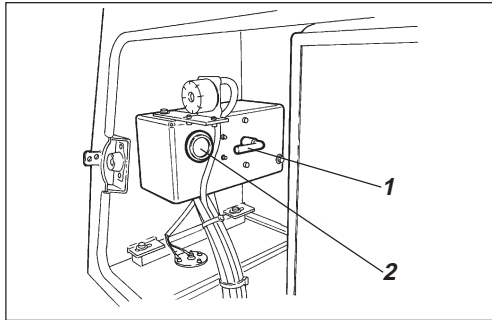

Fig. 8 Engine compartment
1. Battery disconnecter
2. Hourmeter

Remember to carry out daily service. See maintenance manual.

The battery disconnecter is located in the engine compartment. Open the engine cover and set the key (1) to the ON position. The entire roller will be powered.

The hourmeter (2) records the number of hours so long as the engine is running.



WARNING
The engine hood must be unlocked during operation, so that battery power can be disconnected quickly if necessary.

Operator's seat – Setting

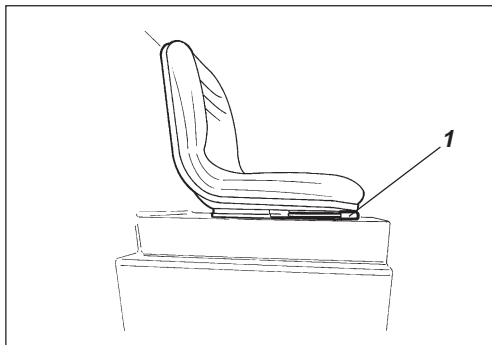

Fig. 9 Operator's seat
1. Locking lever - length adjustment

Adjust the operator's seat to ensure a comfortable posture and so that all controls are within easy reach.

The seat can be adjusted as follows:

- Length adjustment (1)



WARNING
Always make sure that the seat is secure before beginning operation.

Operator's seat in cab (Optional) – Setting

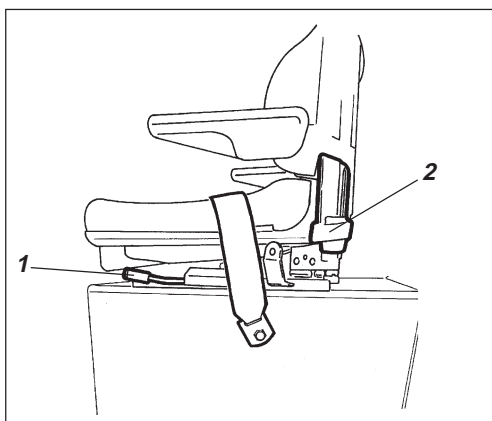

Fig. 10 Operator's seat
1. Locking lever – length adjustment
2. Lever – weight adjustment

Set the operator's seat in a comfortable position and so that the controls are easily accessible.

The seat has the following adjustment facilities:

- Length adjustment (1).
- Weight adjustment (2).



WARNING
Always make sure that the seat is secure before beginning operation.

BEFORE STARTING

Instruments, lamps and field of view – Check

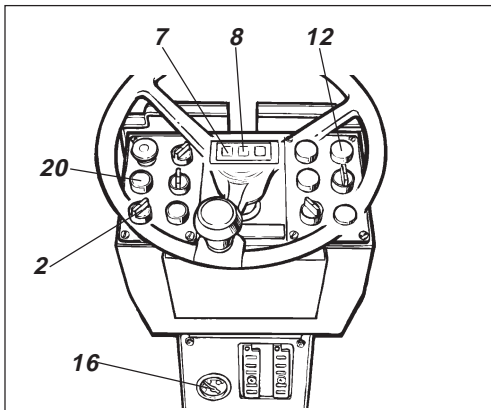

Fig. 11 Instrument panel

- 2. Starter switch
- 7. Charging lamp
- 8. Brake lamp
- 12. Oil pressure lamp
- 16. Fuel gauge
- 20. Test button for warning lamps

Turn the starter switch (2) to position I. Press the button (20) and make sure that all the control lamps light.

Check that the fuel gauge (16) gives a reading.

Check that the warning lamps for charging (7), oil pressure (12), and parking brake (8) light.

Reserve/parking brake – Control

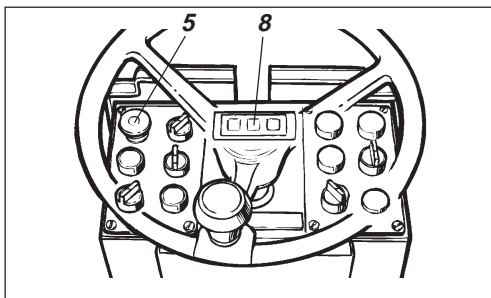

Fig. 12 Control panel

- 5. Reserve/parking brake knob
- 8. Brake lamp

WARNING



Ensure that the reserve/parking brake knob (5) is pressed down. If the parking brake is not applied, the roller may start to roll when you start the engine on sloping ground.

Operator's station

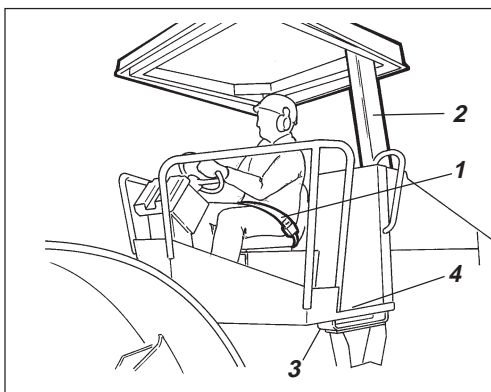

Fig. 13 Operator's station

- 1. Seat belt
- 2. ROPS
- 3. Rubber element
- 4. Anti-slip

If the roller is equipped with a ROPS (2) (Roll Over Protective Structure) or a cab, always use the seat belt (1) and wear a hard hat.

WARNING



Replace the seat belt (1) if it shows signs of wear or has been subjected to severe force.

CAUTION



Check that the rubber elements (3) on the platform are intact. Worn elements will impair comfort.

CAUTION



Ensure that the anti-slip (4) on the platform is in good condition; replace with new anti-slip if friction is poor.

WARNING



If the machine is fitted with a cab, make sure that the door is closed when in motion.

BEFORE STARTING

Field of view

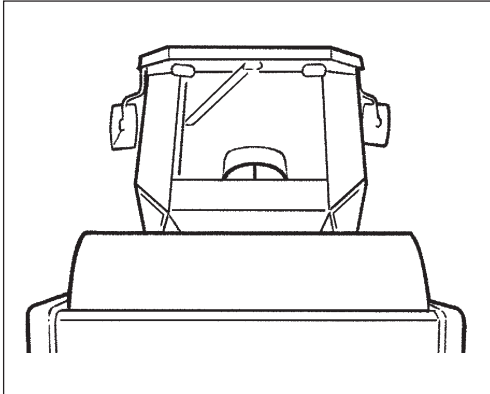

Fig. 14 Field of view

Before starting, make sure that the field of view is unobstructed, both in front and behind. All cab windows must be clean and rearview mirrors properly adjusted.

STARTING

Starting the engine

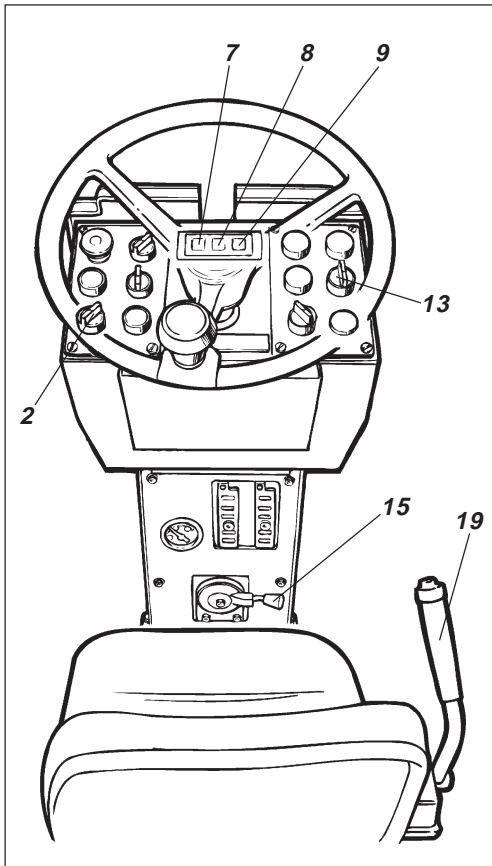

Fig. 15 Instrument panel

- 2. Starter switch
- 7. Charging lamp
- 8. Brake lamp
- 9. Oil pressure lamp/temperature lamp
- 13. Amplitude selector
- 15. Revs control
- 19. Forward/Reverse lever

Set the forward/reverse lever (19) in neutral. The engine cannot be started if the lever is in any other position.

Set the amplitude selector (13) for Low/High vibration to **O** mode.

Set the revs control (15) to idling mode.

Turn the starter switch (2) to the right to the starting mode and release the knob immediately when the engine starts.



Do not run the starter motor too long. If the engine does not start immediately, wait a minute or so before making a new attempt.

Warm up the engine for a few minutes with the rev control in the idling mode, longer if the ambient temperature is below +10°C (+50°F).

Check while warming up that the warning lamps for oil pressure (9) and charging (7) are out. The warning lamp (8) for the parking brake should still light.



When you start up and drive a cold machine, the hydraulic fluid is cold, and the braking distance will be longer than normal until the machine reaches normal working temperature.



Ensure that ventilation (extraction) is adequate if the engine is run indoors. Risk of carbon monoxide poisoning.

OPERATION

Driving the roller

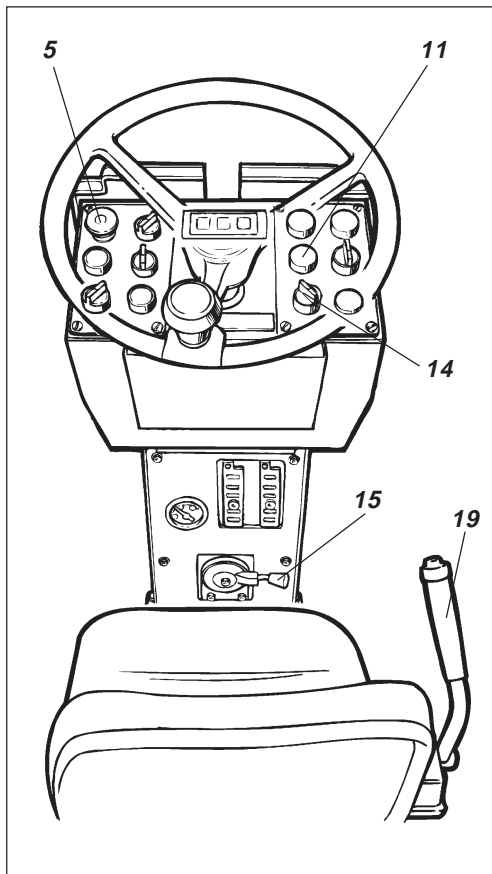

Fig. 16 Instrument panel

- 5. Reserve/parking brake knob
- 11. Warning lamp, air filter
- 14. Speed selector, rear axle
- 15. Rev control
- 19. Forward/Reverse lever

WARNING



Under no circumstances may the machine be operated from the outside. The operator must remain seated inside the machine during all operation.

Turn the rev control (15) upward and latch it at its limit. The engine speed should be about 2300 r/min.

Check that the steering is working by turning the steering wheel once to the right and once to the left, while the roller is stationary.

WARNING



Ensure that the area in front of and behind the roller is clear.

WARNING



Pull up the reserve/parking brake knob (5) and check that the warning lamp for the parking brake is out. When starting the roller on a slope, be prepared that it may begin to roll.

Set the High/Low speed selector (14) to the desired mode (optional feature), see decal on the instrument panel.

Max-speeds, km/h (mph)

Std/P	D	PD
7,5 (4.7)	5 (3.1)	5 (3.1)

Dualspeed, rear axle

	Std/P	D	PD
	7,5 (4.7)	5 (3.1)	5 (3.1)
	18,5 (11.5)	9 (5.6)	9 (5.6)

WARNING



The high mode may only be used for transport runs on an even surface.

Carefully move the forward/reverse lever (19) in the desired direction of travel.

Speed increases as the lever is moved farther from the neutral position.

CAUTION



Always regulate speed with the forward/reverse lever and never by changing the engine speed.

WARNING



Check operation of the reserve/parking brake by pressing the reserve/parking brake knob (5) while the roller is running slowly forward.

Check occasionally while driving that no lamps light. If the oil pressure lamp lights, stop the roller and the engine immediately. Check and remedy any fault; see also the maintenance manual and the engine manual.

CAUTION



If the warning lamp (11) for the air cleaner lights during operation (at full engine revs), the main filter must be cleaned or replaced; see Maintenance Manual.

Low/High amplitude – Setting

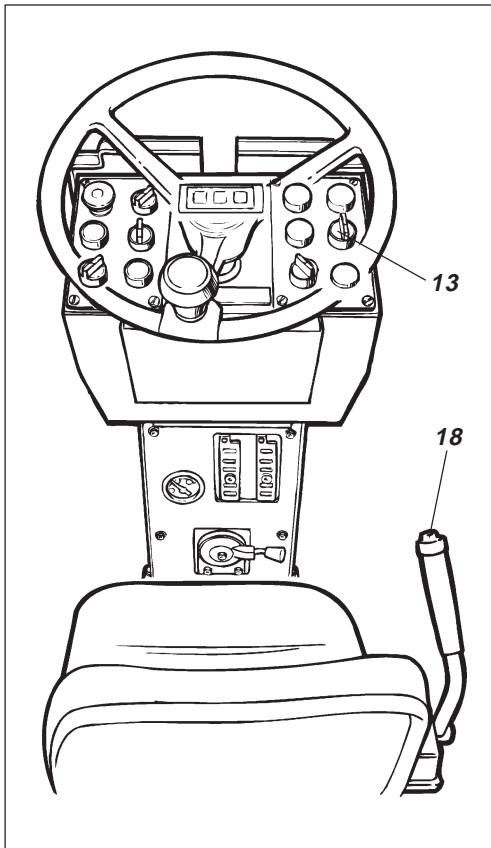

Fig. 17 Instrument panel
13. Amplitude selector
18. Vibration ON/OFF

Drum vibration can be set in two modes, selected using the switch (13). Turn the knob to the left mode for low amplitude, to the right mode for high amplitude.



Never alter the amplitude setting while the vibration is running. Switch vibration off first and wait until it has ceased before altering the amplitude.

Engagement and disengagement of vibration is made with the switch (18) on top of the forward/reverse lever. Always switch off vibration before the roller comes to a complete standstill.



Never allow vibration to be on when the roller is stationary; this may damage the surface and the machine.

BRAKING

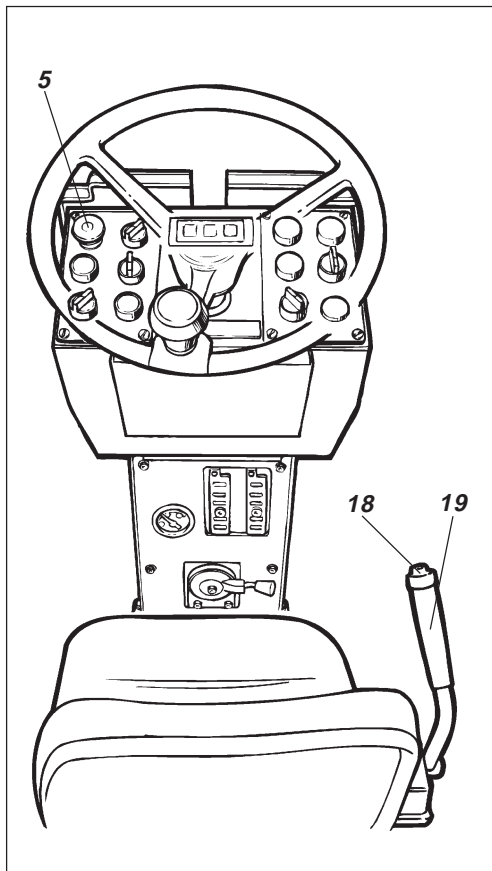

Fig. 18 Control panel

- 5. Reserve brake knob
- 18. Vibration switch ON/OFF
- 19. Forward/Reverse lever

Braking is normally done with the forward/reverse lever (19). The hydrostatic transmission brakes the roller when the lever is moved toward neutral. In addition, multi-disc brakes in the rear axle act as a parking brake and are activated when the reserve brake knob (5) is pressed in.



WARNING
To brake in an emergency, press the reserve/parking brake knob (5), hold the steering wheel firmly and be prepared for a sudden stop.

After braking, restore the forward/reverse lever to neutral and pull up the reserve/parking brake knob.

Normal braking

Press the switch (18) to disengage vibration.

Move the forward/reverse lever (19) to neutral to stop the roller.



WARNING
Always press the parking brake knob (5), even for brief stops on sloping ground.

Turn the speed control back to idling, allow the engine to idle a few minutes to cool down.



WARNING
When starting up and driving a cold machine, which implies cold hydraulic fluid, the braking distance will be longer than normal until the machine reaches working temperature.

Switching off

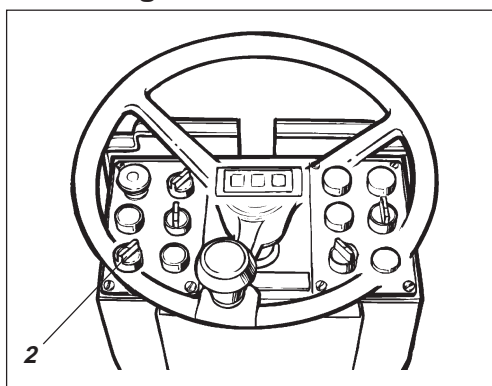

Fig. 19 Instrument panel

- 2. Starter switch

Check instruments and warning lamps to see if any faults are indicated. Switch off all lights and other electrical functions.

Turn the starter switch (2) to mode **O**. Lower the instrument cover (on rollers without cab) and lock it.

PARKING

Chocking the drum

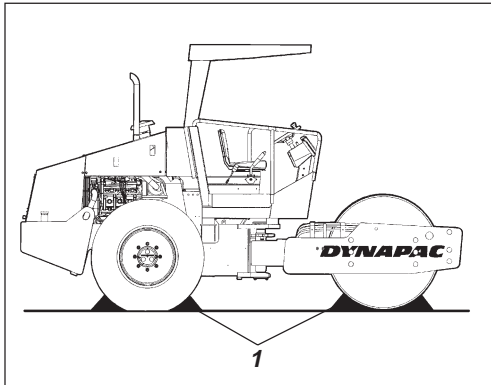

Fig. 20 Chocking the drum
1. Chock

WARNING



Never leave the machine with the engine running unless the reserve/parking brake knob is pressed in.

WARNING



Make sure the roller is parked safely and is not a traffic hazard. Chock the drums when parking on sloping ground.

CAUTION



Remember the risk of freezing during the winter. Fill the engine cooling system and the screenwash bottle in the cab with suitable anti-freeze mixtures. See also the Maintenance Manual.

Battery disconnecter

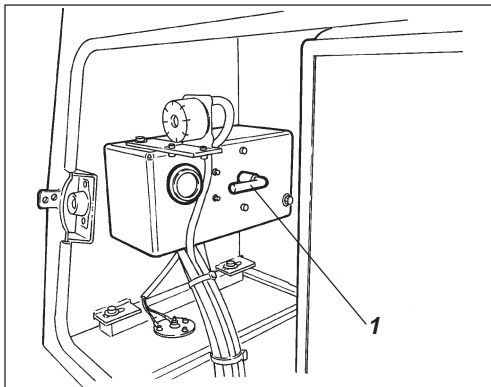

Fig. 21 Tractor frame, rear left
1. Battery disconnecter

Switch the battery disconnecter (1) into disconnected mode and remove the key before leaving the roller.

This will prevent discharging of the battery and will also make it difficult for any unauthorized person to start and drive the machine. Also lock the engine compartment cover.

LIFTING

Locking the articulated joint

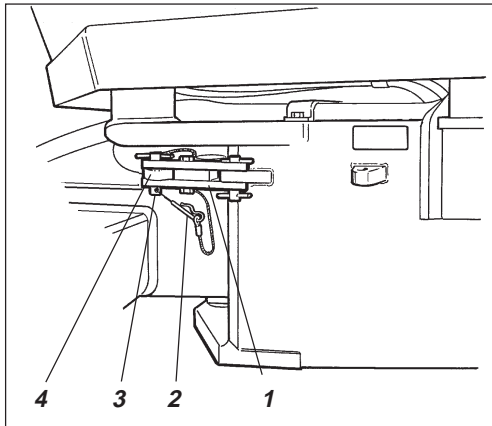

Fig. 22 Articulation in interlocked mode

1. Locking arm
2. Locking cotter
3. Locking stud
4. Locking lug



Articulation must be locked to prevent inadvertent turning before lifting the roller.

Turn the steering wheel so that the machine is set to drive straight forward. Push in the reserve/parking brake knob.

Pull out the lowermost locking cotter (2) fitted with a wire, pull up locking stud (3) fitted with a wire.

Fold out the locking arm (1) and secure it to the upper locking lug (4) on rear machine frame.

Fit the locking stud (3) in the holes through the locking arm (1) and locking lug (4) and secure the stud in position with the locking cotter (2).

Lifting the roller

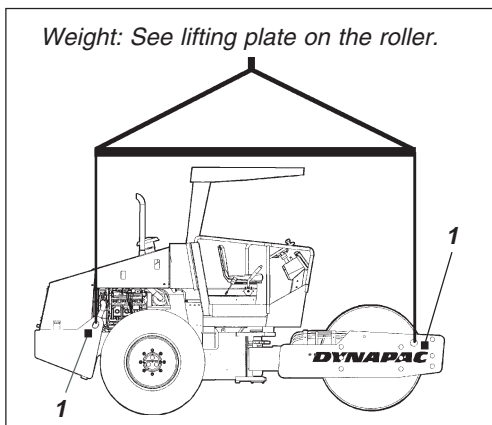

Fig. 23 Roller prepared for lifting

1. Lifting plate



The gross weight of the machine is noted on the lifting plate (1). See also technical specifications in the maintenance instructions.



Lifting gear, such as chains, steel wires, straps, and lifting hooks must be dimensioned in conformance with current regulations.



Keep well clear of the lifted machine! Make sure that lifting hooks are securely anchored.

Releasing the articulated joint

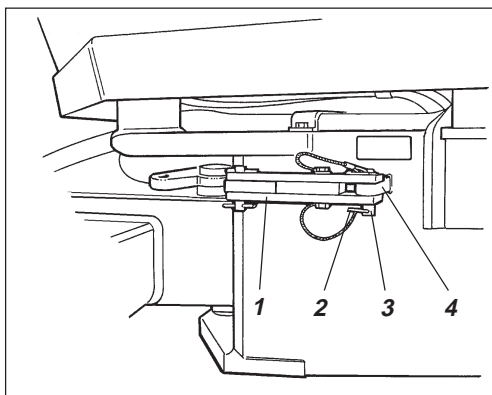

Fig. 24 Articulation in open mode

1. Locking arm
2. Locking cotter
3. Locking stud
4. Locking lug



Remember to restore the articulation interlock to its open mode before driving again.

Fold back the locking arm (1) and secure it in the locking lug (4) with the locking stud (3). Insert the lowermost locking cotter (2) fitted with a wire, to secure the locking stud (3). The locking lug (4) is located on the tractor frame.

TOWING

Alternative 1 Towing short distance with engine working

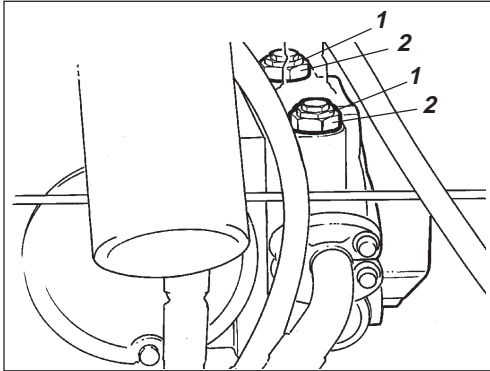

Fig. 25 Propulsion pump
1. Towing valve
2. Locknut

The roller may be moved a distance of up to 300 metres (330 yards) using either of the following alternatives.



Press the reserve/parking brake knob, and stop the engine temporarily. Chock the drums to prevent the machine from rolling.

Open the engine hood. Turn both towing valves (1) (middle hexagonal nut) three turns counter clockwise, while holding the multifunction valve (2) (lowest hexagonal nut) in place. The valves are located on the upper side of the propulsion pump.

Start the engine and allow it to idle.

The roller can now be towed and can also be steered if the steering system is in action.

Alternative 2 Towing short distance with engine not working

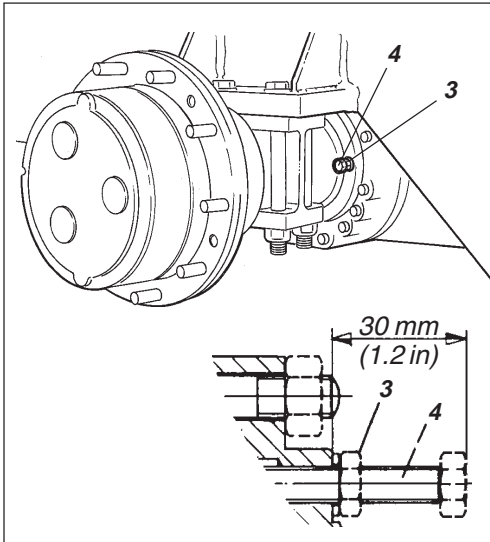

Fig. 26 Rear axle
3. Locknut
4. Adjusting screw



Chock the drums as a precaution so the roller does not begin to move when the brakes are disengaged mechanically.

First, open both of the towing valves according to alternative 1 above.

Rear axle brake

Undo the locknut (3) and adjust the adjustment screws (4) by hand until resistance increases, and then one additional turn. The adjustment screws are located on the rear axle, two screws on each side of the differential housing.



After towing, remember to tighten the towing valves (1). Screw out the adjusting screws (4) to their initial position 30 mm (1.2 in) from the contact surface, and tighten the locknuts (3). Tighten the four hexagonal socket screws (5).

INSTRUCTIONS FOR TOWING

Disengaging the drum brake

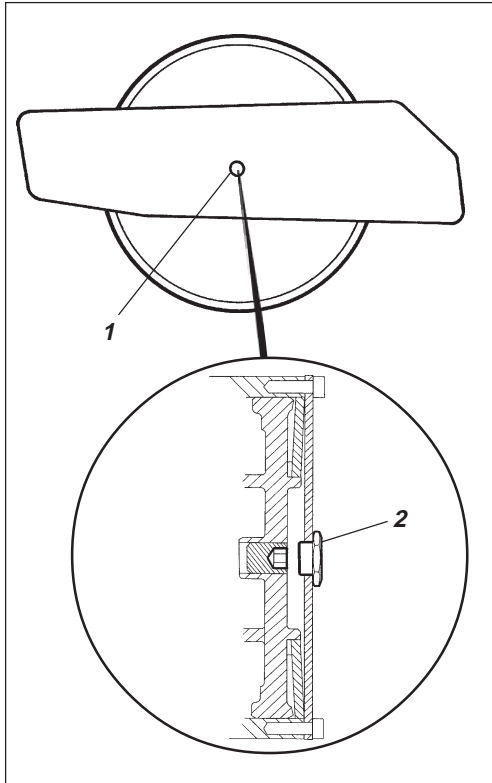

Fig. 27 Left frame side

1. Centre hole
2. Centre plug

Drum motor brake (Optional)

Screw off the center plug (2) of the drum brake, which is accessible through the center hole (1) in the left side of the frame.

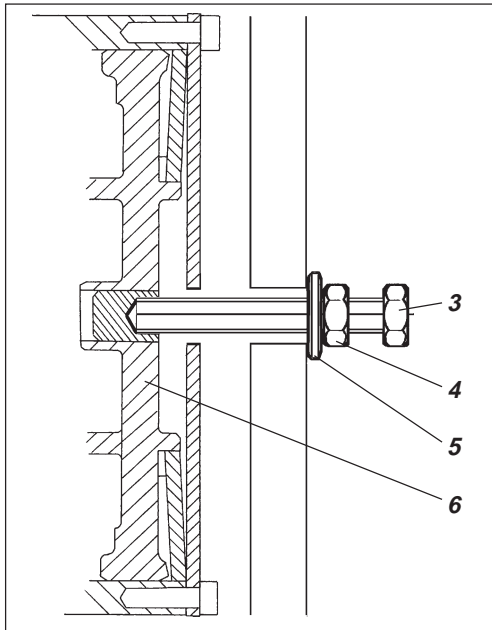

Fig. 28 Sectional view of brake housing

3. Bolt
4. Nut
5. Washer
6. Brake piston

Screw in the bolt (3) to the bottom according to the figure. Now screw in the nut (4) so that it lies against the washer (5) and then a further 1 1/2 inch while holding the bolt (3).

The brake is now disengaged and the roller can be towed.



After towing, remember to reset the towing valves (1). Unscrew the adjusting screw (4) to its initial position 26 mm (1 inch) from the contact surface, and tighten the lock nuts (3). Also reset the brake of the drum motor.

TOWING/RETRIEVAL

Towing a roller

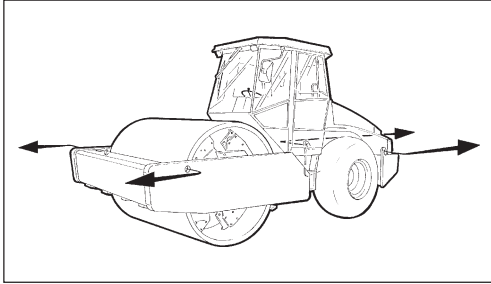

Fig. 29 Towing

WARNING



The roller must be counter-braked when towing. Use a towbar because the roller will have no ability to brake.

CAUTION



The roller must be towed slowly, max. 3 km/h (2 mph) and for a short distance only, max. 300 m (330 yards).

When a machine is towed/retrieved, the towing device must be connected to both lifting holes. Pulling forces shall act longitudinally on the machine as illustrated. Maximum gross pulling force 120 kN (27 lbf).

CAUTION



Restore the items for towing according to alternative 1 or 2 on the preceding page.

TRANSPORT

Roller prepared for transport

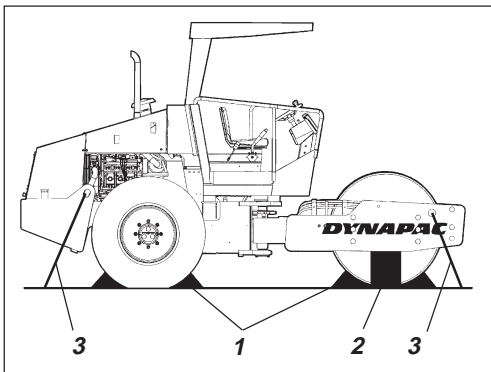

Fig. 30 Transportation

1. Chocks
2. Supporting blocks
3. Lashing wire

Chock the drums (1) and secure the chocks to the transport vehicle.

Block up under the drum frame (2), to avoid overload on the rubber suspension of the drum when lashing.

Clamp down the roller with lashing strap (3) at all four corners; decals indicate the fixing points.

CAUTION



Remember to restore the articulation interlock to its open mode before starting the roller again.

OPERATING INSTRUCTIONS - SUMMARY



1. Follow the **SAFETY INSTRUCTIONS** in the **Safety Manual**.
2. Ensure that all instructions in the maintenance manual are followed.
3. Turn the battery disconnecter to on.
4. Move the forward/reverse lever to neutral.
5. Set the vibration selector to the **O** mode.
6. Set the revs control to the idling mode.
7. Start the engine and allow it to warm up.
8. Set the revs control in the operating mode.
9. Put the reserve/parking brake knob in the pulled-out position.



10. **Drive the roller. Operate the forward/reverse controls with care.**



11. **Test the brakes.**
Remember that the braking distance will be longer if the roller is cold.

12. Use the vibration only when the roller is in motion.



13. **IN AN EMERGENCY:**
 - **Push in the reserve/parking brake knob.**
 - **Hold the steering wheel firmly.**
 - **Brace yourself for a sudden stop.**

14. Parking: Push in the reserve/parking brake knob. Stop the engine and chock the drums.

15. Lifting: – See the operation manual.

16. Towing: – See the operation manual.

17. Transport: – See the operation manual.

18. Retrieval: – See the operation manual.